



# TECHNOLOGY AND DEMONSTRATORS

## Technical Report Subtask B – Part B3

B3: Case studies

## Technical Report Subtask C – Part C2

C2: Analysis of built best practice examples and conceptual feasibility studies

**Franz Mauthner**

AEE INTEC  
Gleisdorf, Austria

















**Martin Joly**

Sorane SA  
Ecublens, Switzerland



With contributions from:

<p><b>Daniel Trier, Linn Laurberg Jensen</b> PlanEnergi Zealand Copenhagen, Denmark</p>	
<p><b>Bengt Perers, Simon Furbo, Zhiyong Tian</b> Technical University of Denmark Copenhagen, Denmark</p>	
<p><b>Sebastian Herkel, Mehmet Elci, Axel Oliva</b> Fraunhofer-Institute for Solar Energy Systems Freiburg, Germany</p>	
<p><b>Christine Weber</b> BKW AG Bern, Switzerland</p>	
<p><b>Gabriel Ruiz</b> CREM - Centre de Recherches Energétiques et Municipales Martigny, Switzerland</p>	
<p><b>Martin Andersen, Jan-Olof Dalenbäck</b> Dalarna University / Chalmers University of Technology Falun / Gothenborg, Sweden</p>	
<p><b>Martin Joly</b> Sorane SA Ecublens, Switzerland</p>	
<p><b>Franz Mauthner</b> AEE INTEC Gleisdorf, Austria</p>	
<p>Apart from the above mentioned participants of IEA SHC Task 52, the following companies and institutions provided valuable inputs to the respective best practice examples:</p>	
<p><b>Johan Frey</b> Dronninglund Fjernvarme A.m.b.a. Dronninglund, Denmark</p>	

<p><b>Andreas Zourellis</b> Aalborg CSP A/s Aalborg, Denmark</p>	 <p><b>AALBORG CSP</b> - Changing Energy</p>
<p><b>Norbert Dorfinger</b> Salzburg AG für Energie, Verkehr und Telekommunikation Salzburg, Austria</p>	 <p><b>SALZBURG AG</b></p>
<p><b>Inge Strassl</b> SIR - Salzburg Institute for Regional Planning and Housing Salzburg, Austria</p>	 <p><b>SIR</b></p>
<p><b>Alexander Ripka</b> badenovaWÄRMEPLUS GmbH &amp; Co. KG Freiburg i.Br., Germany</p>	 <p><b>badenova WÄRMEPLUS</b> Intelligente Lösungen. Tag für Tag</p>
<p><b>Fabien Kuchler</b> Lauber IWISA AG Naters, Switzerland</p>	 <p><b>Lauber</b> IWISA</p>
<p><b>Bernard Thissen</b> Energie Solaire S.A. Sierre, Switzerland</p>	 <p><b>ENERGIE SOLAIRE</b></p>

## IEA Solar Heating and Cooling Programme

The Solar Heating and Cooling Programme was founded in 1977 as one of the first multilateral technology initiatives ("Implementing Agreements") of the International Energy Agency. Its mission is *"to enhance collective knowledge and application of solar heating and cooling through international collaboration to reach the goal set in the vision of solar thermal energy meeting 50% of low temperature heating and cooling demand by 2050."*

The member countries of the Programme collaborate on projects (referred to as "Tasks") in the field of research, development, demonstration (RD&D), and test methods for solar thermal energy and solar buildings.

A total of 53 such projects have been initiated to-date, 39 of which have been completed. Research topics include:

- ✦ Solar Space Heating and Water Heating (Tasks 14, 19, 26, 44)
- ✦ Solar Cooling (Tasks 25, 38, 48, 53)
- ✦ Solar Heat or Industrial or Agricultural Processes (Tasks 29, 33, 49)
- ✦ Solar District Heating (Tasks 7, 45)
- ✦ Solar Buildings/Architecture/Urban Planning (Tasks 8, 11, 12, 13, 20, 22, 23, 28, 37, 40, 41, 47, 51, 52)
- ✦ Solar Thermal & PV (Tasks 16, 35)
- ✦ Daylighting/Lighting (Tasks 21, 31, 50)
- ✦ Materials/Components for Solar Heating and Cooling (Tasks 2, 3, 6, 10, 18, 27, 39)
- ✦ Standards, Certification, and Test Methods (Tasks 14, 24, 34, 43)
- ✦ Resource Assessment (Tasks 1, 4, 5, 9, 17, 36, 46)
- ✦ Storage of Solar Heat (Tasks 7, 32, 42)

In addition to the project work, there are special activities:

- SHC International Conference on Solar Heating and Cooling for Buildings and Industry
- Solar Heat Worldwide – annual statistics publication
- Memorandum of Understanding – working agreement with solar thermal trade organizations
- Workshops and conferences

### Country Members

Australia	Germany	Singapore
Austria	France	South Africa
Belgium	Italy	Spain
China	Mexico	Sweden
Canada	Netherlands	Switzerland
Denmark	Norway	Turkey
European Commission	Portugal	United Kingdom

### Sponsor Members

European Copper Institute	Gulf Organization for Research and Development
ECREEE	RCREEE
	ISES

### Further information:

For up to date information on the IEA SHC work, including many free publications, please visit [www.iea-shc.org](http://www.iea-shc.org).

## Content

1	Scope and content of Subtask C	6
2	Scope and content of Subtask B	6
3	Methodology	6
4	Analysis of best practice examples and feasibility studies	7
4.1	Solar district heating with seasonal storage in the city of Dronninglund, DK.....	8
4.2	Hybrid solar district heating in the city of Taars, DK .....	18
4.3	Solar-assisted urban quarter “Salzburg-Lehen”, AT .....	25
4.4	Solar-assisted urban quarter “Freiburg-Gutleutmatten”, DE.....	33
4.5	Solar-assisted residential area “Vallda Heberg” in Kungsbacka, SE .....	41
4.6	Solar assisted apartment blocks “La Cigale” in Geneva, CH.....	50
4.7	Solar-assisted mountain holiday resort “Reka Feriendorf” in Naters, CH.....	58
4.8	Solar-assisted urban quarter “Buchsee-Köniz” in Berne, CH .....	65
4.9	Solar-assisted urban quarter “Renens-CFF” in the suburb of Lausanne; CH ....	71
5	Literature References	76

## 1 Scope and content of Subtask C

In the framework of IEA-SHC Task 52 the future role of solar thermal in urban energy systems is investigated. In Subtask C “*Technology and Demonstrators*” an overview and analysis over corresponding state-of-the-art applications is given.

In Report [C1: Classification and benchmarking](#), solar thermal system configurations suitable for applications in urban environments are identified and characterized by representative techno-economic benchmark figures from a set of best practice examples. Objective is to provide a comprehensive data base for techno-economic (pre-) evaluations, especially applicable for urban planners / energy system planners without deeper theoretical solar thermal expertise.

In Report [C2: Analysis of best practice examples](#), information about built best practice examples as well as conceptual feasibility studies of solar thermal applications in urban environments is summarized. Objective is to highlight technical potentials, innovative approaches and restrictions of solar thermal applications in urban environments in a holistic energy system context on the one hand and to identify and describe lessons learned regarding applied methodologies, success factors and barriers on the other side.

In addition, a [Best-practice Leaflet](#) provides flash light information and impressions about seven best practice examples from Austria, Denmark, Germany, Sweden and Switzerland. The examples represent the entire range of solar thermal system configurations suitable for applications in urban environments including systems, which are hydraulically connected to a district or block heating grid, as well as systems which are directly attached to individual buildings.

## 2 Scope and content of Subtask B

Subtask B “*Methodologies, Tools and Case studies*” aims at providing methodologies to support technical and economical calculations and decision paths for successful integration of solar thermal applications in urban environments. The intention is to identify urban planning methodologies and calculation techniques capable to ensure an objective evaluation of the role of solar thermal in urban energy scenario’s reflecting future regional, national and international boundary conditions.

The use of solar thermal can be differently weighted depending on the size and the boundary of the concerned energetic systems. In Subtask B, case studies for integrating solar thermal systems into urban and regional energy systems were performed.

This document, compiled with Subtask C, represents the deliverable [B2: Report on Case studies](#).

## 3 Methodology

The analysis of built best practice examples and conceptual feasibility studies is based on information gathered in the framework of a comprehensive questionnaire survey. For each case, information about both technology specific aspects as well as non-technological aspects was asked.

Each case description (chapters 4.1 to 4.9) follows the same sub-chapter structure:

- 4.x.1 Introduction and description
- 4.x.2 Technical description of the concept and innovative approaches
- 4.x.3 Decision and design process
- 4.x.4 Lessons learned (barriers and success factors)
- 4.x.5 Summary

## 4 Analysis of best practice examples and feasibility studies

In sum, nine questionnaires were filled-in by Task participants in co-operation with involved stakeholders such as city council departments, real estate developers, local utilities and technical consultants. Case Studies from Denmark, Sweden, Germany, Austria and Switzerland are described.

CaseNr	BP	FS	Title of case study	Country
1	✓	✗	Solar district heating with seasonal storage in the city of Dronninglund, DK	DK
2	✓	✗	Hybrid solar district heating in the city of Taars, DK	DK
3	✓	✗	Solar-assisted urban quarter "Salzburg-Lehen", AT	AT
4	✓	✗	Solar-assisted urban quarter "Freiburg-Glutleutmatten", DE	DE
5	✓	✗	Solar-assisted residential area "Vallda Heberg" in Kungsbacka, SE	SE
6	✓	✗	Solar assisted apartment blocks "La Cigale" in Geneva, CH	CH
7	✓	✗	Solar-assisted mountain holiday resort "Reka Feriendorf" in Naters, CH	CH
8	✗	✓	Solar-assisted urban quarter "Buchsee-Köniz" in Berne, CH	CH
9	✗	✓	Solar-assisted urban quarter "Renens-CFF" in the suburb of Lausanne; CH	CH

\*BP...built best practice example

\*\*FS...conceptual feasibility study

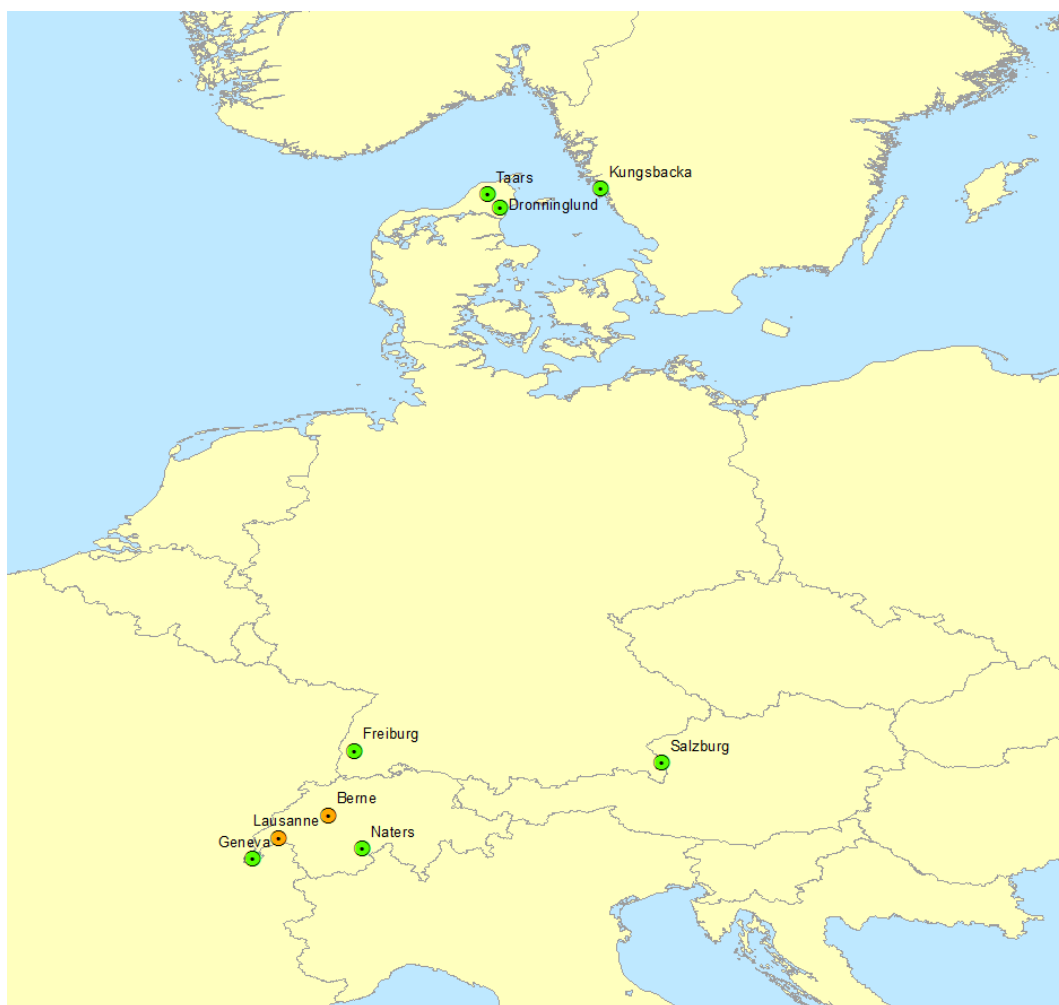

Figure 1: Location of the investigated case studies (green: built best practice example, orange: conceptual feasibility study)



## 4.1 Solar district heating with seasonal storage in the city of Dronninglund, DK

### Authors:

Daniel TRIER	PlanEnergi	<a href="mailto:dt@planenergi.dk">dt@planenergi.dk</a>
Linn Laurberg JENSEN	PlanEnergi	<a href="mailto:llj@planenergi.dk">llj@planenergi.dk</a>



**Figure 2: Aerial view on the solar district heating system of Dronninglund Fjernvarme** (Source: Brønderslev Municipality). A flat plate collector field (1by) with a gross collector area of 40,466 m<sup>2</sup> hydraulically connected to a 62,000 m<sup>3</sup> pit thermal energy storage (29k) as well as to an absorption heat pump with 2.6 MW<sub>th</sub> heating capacity for improved operation flexibility was put into operation in 2014. From 06/2015-05/2016 48 % of the annual DH output originated from solar thermal.



**Project fact box /2/, /3/:****General information:**

Location: **Northern Denmark (Jutland), Brønderslev Municipality**  
 Urban scale of area: **633 km<sup>2</sup> (municipality) / 2.8 km<sup>2</sup> (city)**  
 Population in the area: **36,047 (municipality) / 3,394 (city); 2016**  
 Building mix in the area (city): **Mainly single-family homes, few multi-storey buildings**  
 Plant owner: **Consumer-owned cooperative with limited liability (Dronninglund Fjernvarme A.m.b.A)**

**Specific information about Dronninglund Fjernvarme A.m.b.A:**

Heated (gross) floor area (supplied by district heating): **approx. 309,000 m<sup>2</sup> (2015/16)**  
 Final thermal energy consumption (heat generated, incl. thermal losses): **35.726 MWh (2015/16)**  
 Useful thermal energy consumption (heat sold): **27.652 MWh (2015/16)**  
 Network heat losses: **8,074 MWh (2015/16) (22.6 %)**  
 Heating grid trench length: **46 km (only distribution grid, length of service pipes not considered)**  
 No. of building substations: **approx. 1,350**  
 Supply/Return temperature levels: **Supply 75°C, return 40°C**  
 (Thermal) energy supply technologies: **N-Gas CHP (5.9 MW<sub>th</sub>/3.7 MW<sub>el</sub>), bio-oil boiler (10 MW<sub>th</sub>), N-Gas boiler (8 MW<sub>th</sub>), solar thermal (26.3 MW<sub>th</sub>), absorption heat pump (2.6 MW<sub>th</sub> heating)**

**Specific information about the solar thermal part:**

Solar thermal collector area: **40,466 [m<sup>2</sup><sub>gross</sub>] / 37,573 [m<sup>2</sup><sub>aperture</sub>] (2,982 panels)**  
 Thermal energy storage: **Pit heat storage (seasonal storage): approx. 62,000 m<sup>3</sup>; tank thermal energy storage (diurnal storage, load balancing): 865 m<sup>3</sup>**  
 Annual solar energy yield: **17,201 MWh (06/2015-05/2016 [\*] /1/**  
 Solar fraction: **48% (based on heat generated resp. final DH output)**  
 Specific annual solar energy yield: **425 kWh/ (m<sup>2</sup><sub>gross</sub>·a) / 458 kWh/ (m<sup>2</sup><sub>aperture</sub>·a), 2015/2016**

**Economics of the solar thermal part:**

Total project cost: **14.63 M EUR (excl. VAT); grant/funding (excl. VAT): 2.95 M EUR (20.2%)**

<i>Solar thermal collector field incl. piping and foundations</i>	<b>41.7%</b>
<i>Pit heat water storage incl. heat exchanger, pumps, piping</i>	<b>16.4%</b>
<i>Technique building with pipes, pumps, heat exchangers, control</i>	<b>16.4%</b>
<i>New district heat piping, excavation and mounting</i>	<b>9.1%</b>
<i>Oil boilers / absorption heat pump</i>	<b>6.3%</b>
<i>Land / contingencies</i>	<b>5.5%</b>
<i>Consulting / engineering</i>	<b>4.6%</b>

[\*] From <http://solarheatdata.eu/> (accessed on 01/2017)

#### 4.1.1 Introduction and description

##### History of Dronninglund district heating /3/, /4/

Dronninglund Fjernvarme A.m.b.A was established in 1973 as a consumer-owned cooperative with limited liability (as most other district heating (DH) utilities in Denmark). Initially, heat supply was exclusively based on oil boilers. In 1989, it became the first Danish district heating company to install natural gas-driven engines for combined heat and power production. Around 2005, the board and the general assembly of Dronninglund Fjernvarme realized that they should replace natural gas with renewable energy over time.

At that time, several Danish district heating utilities had already gained experiences with large scale solar thermal systems that could cover up to 20 % of the annual district heating demand **without increasing consumer heat prices**. Dronninglund Fjernvarme decided to go further and targeted a **solar fraction of 50 %**. In 2007, *Nordjyllands Vækstforum* (forum for regional business) subsidized a pre-feasibility study. From a technical perspective the study showed that a **large-scale solar thermal system combined with a seasonal storage** could meet this objective. Moreover, it has been found that the heat production price would not be increased for the consumer with a subsidized investment. Consequently, Dronninglund Fjernvarme decided to continue the project and applied for subsidy from EUDP (Energy Technology Development and Demonstration Programme), a program financed by the Danish state. The application was approved and subsidy was granted for detailed design and for investments in long-term storage, piping, heat exchangers and a control system to connect the production units (subsidy amounted to around 20 % of the entire system cost – see fact box).

New Dronninglund solar-assisted district heating system with seasonal pit heat storage was put into operation in May 2014. By end of 2016, the district heating utility supplies around 1,350 consumers via 46 km of district heating network. In the period 06/2015-05/2016 48 % of the annual district heat output originates from solar thermal.



**Figure 3:** Pit heat storage in Dronninglund with the solar collector field seen in the back (Source: Dronninglund Fjernvarme A.m.b.A)

#### 4.1.2 Technical description of the concept and innovative approaches

The main components in the new production plant are the large solar thermal plant hydraulically connected to seasonal pit heat water storage as well as to an absorption heat pump (Figure 4).

Overall, the Dronninglund district heating system comprises the following system components:

- Four natural gas CHP units (approx. 5.9 MW of heat and 3.7 MW electricity)
- 865 m<sup>3</sup> non-pressurized tank thermal energy storage for load balancing
- Bio oil boiler (10 MW<sub>th</sub> in regular hot water mode for peak load resp. 6 MW<sub>th</sub> in superheated hot water mode for absorption heat pump operation)
- 8 MW<sub>th</sub> N-Gas hot water boiler as backup heating system

- Absorption heat pump (approx. 2.6 MW<sub>th</sub> heating / 2.1 MW<sub>th</sub> cooling capacity).
- Pit heat storage (approx. 62,000 m<sup>3</sup>)
- Ground-mounted collector field (2,982 solar thermal collectors with a total of 37,573 m<sup>2</sup> aperture area – corresponding to a thermal peak capacity of 26.3 MW)

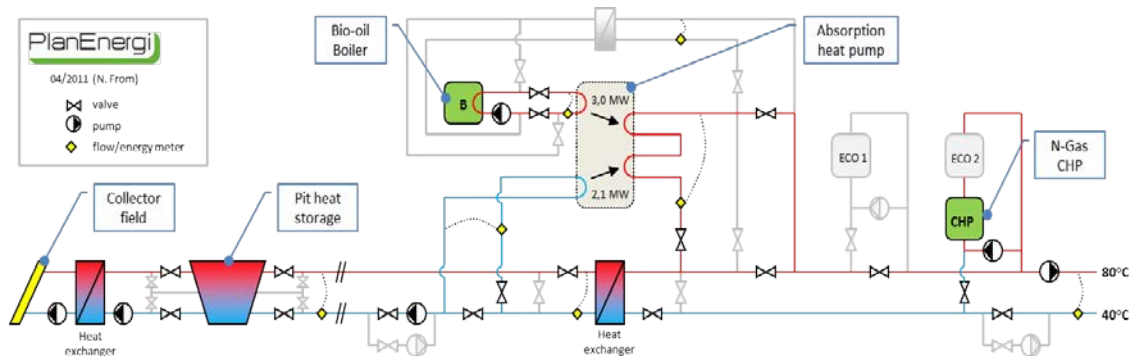

**Figure 4: Dronninglund District heating principle diagram including solar thermal collector field, pit heat storage and absorption heat pump** (Source: PlanEnergi) *Note: the diagram is simplified and not all equipment is shown*

### Operating principle and seasonal operating modes:

In summer (non-heating season), solar thermal energy supply by far exceeds thermal energy demand of the connected consumers in Dronninglund. The surplus is used to heat up (charge) the pit heat storage to a maximum temperature of 90 °C (limited by the liner material). In autumn (heating season), hot water is taken out from the upper storage part for district heating while the cooler district heating return flow enters the bottom part of the energy storage with a temperature of around 40 °C (discharging). If the temperature from the pit heat storage is lower than the required district heating supply temperature the missing energy may be provided by the absorption heat pump (driven by superheated hot water with 160 °C from the bio-oil boiler). Otherwise, district heating is conventionally supplied in boiler and/or CHP mode.

While heat pump operation, the district heating return flow is used as heat sink and temperature is decreased down to 10 °C (minimum: 8 °C) before water enters the pit heat storage. This has several positive effects on the entire system efficiency: On the one hand, storage capacity is increased meaning that with similar storage volume more energy can be stored (higher  $\Delta T$ ). Second, average storage temperature is decreased which decreases thermal energy storage losses and third, efficiency of the solar thermal collectors is increased due to lower operating temperatures.

### Pit heat storage and lid-design:

More and more utilities in Denmark look towards introducing solar heat or increasing the share of solar heat they already have. Typically, solar fractions of 5-20 % can be reached with short-term (diurnal) storages [1] but for higher solar fractions of up to 50-60 % seasonal storages are needed. Although different concepts for seasonal thermal energy storage are available, pit heat storages are the most promising technology today with several installations realized all over Denmark (e.g. Marstal and Vojens among others).

Solar thermal has in general made progress in recent years in the Danish district heating systems and in 2017 the Danish town of Silkeborg holds the record for having the world's largest solar heating system with a collector aperture area of 156,694 m<sup>2</sup> (corresponding to a thermal peak capacity of 110 MW). There are several reasons for this development; taxes on natural gas (no taxes on solar thermal), prohibition of additional biomass in natural gas-fired power plants as well as one year of

<sup>1</sup> 20 % solar fraction on an annual basis corresponds to about 100 % coverage in the summer months.

solar production can be counted as energy savings the first year of operation. It is also essential that the technology is reliable with a long life (over 25-30 years) and that the industry shares knowledge and experience, e.g. through the Danish District Heating Association [e.g. /5/].

The technology is still relatively young and several R&D agendas have been addressed in the framework of the Dronninglund project:

- Demonstration of full-scale pit heat storage combined with solar thermal and heat pump.
- 50 % solar thermal coverage of district heat demand
- Development and demonstration of improved solutions for the roof-cover [2] and the HDPE-liner which separates the water body from the soil (see schematic diagram in Figure 5)
- Investigations on possible benefits due to multi-functional use of the storage (e.g. additional storage of excess heat from industries, power plants and biogas plants, Power-to-Heat, etc.)

The HDPE-liner used in Dronninglund has a durability of min. 20 years for temperatures up to 90 °C for one storage cycle (charging and discharging – one year). The construction is described in detail in /5/.

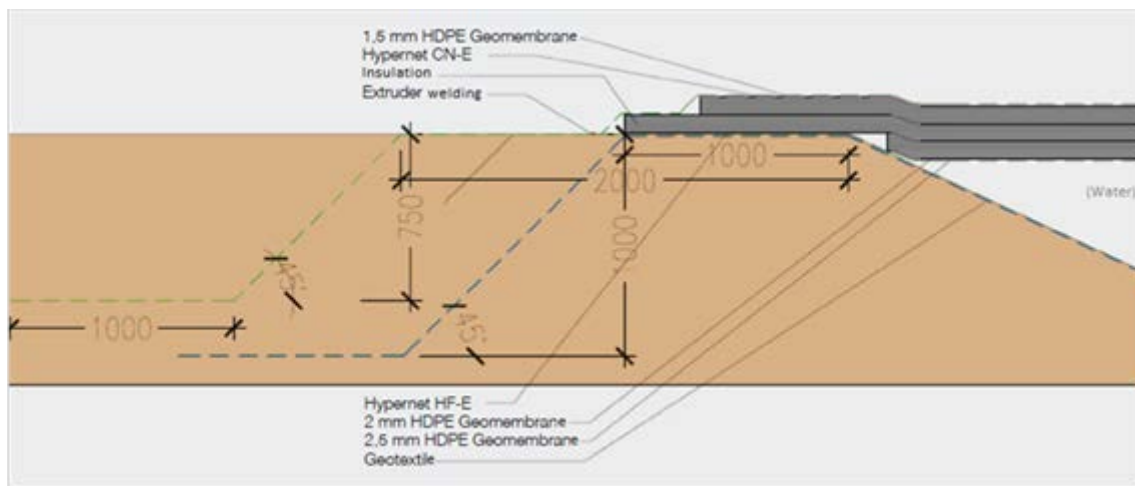

Figure 5: Principle diagram of the pit thermal energy storage and lid design cross section (Source: PlanEnergi from /4/)

One of the major advantages of the pit heat storage is that the cost per  $\text{m}^3$  of storage is relatively low e.g. around 40 €/m<sup>3</sup>. A larger storage than the one in Dronninglund has even achieved lower costs than this (e.g. between 20 and 30 €/m<sup>3</sup>). The marginal investment cost per m<sup>3</sup> is even lower if initial investment costs are disregarded. Hence, if a DH company decides to establish a pit heat storage and considers different size options, then the cost of increasing the volume with an extra m<sup>3</sup> can be very low (e.g. in the range of 15-20 €/m<sup>3</sup>). When considering large scale storages, the investment cost will typically be much lower than steel tank solutions. On the other hand, the initial investment cost of a pit heat storage together with the associated heat losses, makes it unfeasible for smaller storage volumes (e.g. a few thousand m<sup>3</sup>).

<sup>2</sup> Problems that occurred in an earlier installation (10,000 m<sup>3</sup> pit heat storage in Marstal) should be avoided in Dronninglund. Special focus was given to air pockets under the cover, water pits on the top near the edge, moisture in insulation and degrading of the convection barrier.

### 4.1.3 Decision and design process

*The following questions and answers aim at understanding the context (political, urban, energy) and the pre-design steps that led to the retained solution.*

#### **General / organizational issues:**

*Why was this project initiated, to answer which need?*

Due to uncertain price developments of natural gas but also of limited renewable resources such as biomass the board of Dronninglund district heating decided on a strategy for a future heat supply based on high shares from solar thermal energy. As a consequence, "SUNSTORE 3" project was initiated in 2008 with the objective to design, optimize and implement a full-scale solar district heating plant that is able to cover around half of the present heat demand.

In the framework of a feasibility study, a technical concept including 35,000 m<sup>2</sup> collector area, 60,000 m<sup>3</sup> pit heat water storage volume and a MW-scale heat pump was developed to meet this target. Economic calculations showed that the new system has the potential to stabilize district heating prices in the long run and that consumer heat prices need not to be increased if some of the new equipment is subsidized.

*Which stakeholders were involved in the project?*

- District heating utility: Dronninglund Fjernvarme A.m.b.A
- Local authority: Brønderslev municipality
- Main entrepreneur: AEA – Averhoff Energi Anlaeg A/S
- Technical consultants: Planenergi (DK), NIRAS (DK), Solites (DE)
- Others
  - o Solar collector supplier: Arcon Solar A/S
  - o Excavation, storage: Jakobsen & Blindkilde
  - o Liner work, storage: PBJ Milijoe
  - o DH pipe supplier: Logstor
  - o Entrepreneur, transmission pipes: L&H-Roerby
  - o Electrical installations: Dronninglund EL-Service A/S
  - o Control system: DME A/S
  - o Building: JE BYG APS
  - o Boiler and heat pump: danstoker

The project is subsidized from EUDP (Energy Technology Development and Demonstration Programme), a program financed by the Danish state (administrated by the Danish Energy Agency).

*Who (what) were drivers and who (what) were opponents (barriers) – and why?*

In general, the main driver for the project was the initiative of the local district heating utility (Dronninglund Fjernvarme A.m.b.A).

From a technical perspective, to find suitable placement for a pit heat storage can be challenging because soil and groundwater conditions have critical effects on the costs (e.g. if ground water level is above storage bottom level special structural measures are required).

*What have been the main challenges regarding decision finding?*

The first design phase ended up with an *electrical* driven compression heat pump with a thermal heating capacity of 3 MW. However, the compression heat pump showed bad economy due to the Danish electricity taxation system. As a consequence, the technical concept was adapted in favor of an absorption heat pump with a heating capacity of 2.6 MW<sub>th</sub>.



### *What was finally the crucial parameter for go /no-go decision?*

Main arguments were stable heat prices over the system life time (20-30 years) and more flexibility in district heating operation due to the new equipment (solar thermal + seasonal storage + absorption heat pump).

Moreover, it was crucial for Dronninglund district heating that the investment did not increase current end-consumer costs for heat. Financial support was asked from the Danish state-funded *Energy Technology Development and Demonstration Programme* (EUDP). The application was granted due to the innovative approach.

### **Financing issues:**

#### *What have been the main challenges / constraints regarding financing?*

One barrier was a financial one concerning taxes on electricity for the electrical heat pump in the project. Therefore, an absorption heat pump was implemented in the project instead of an electric driven heat pump.

#### *Which business model applies to the project?*

In general the heat price (and potential future lower heat price) is the main driver for the district heating companies' investments. The production price for heat in Dronninglund has no grants included and capital expenses corresponding average costs for a 20 year annuity loan with an interest of 5% and 2% inflation is 374 DKK/MWh (~ 50 €/MWh). The investor in the project is the DH company in Dronninglund. The heat price today for the consumers is 424 DKK/MWh excl. VAT (~ 57 €/MWh).

All grid and distribution companies in electricity, district heating and natural gas is through the Agreement of 13 November 2012 /6/ required to achieve a number of energy savings annually and report these to the Danish Energy Agency (DEA). The first year's solar heat production could count as such an energy saving. The system includes the opportunity to buy other companies' savings instead of obtaining them. Hence, the surplus savings Dronninglund DH obtained by installing the solar field meant that some of the savings could be sold on the "energy savings stock market".

The main commercial objectives in the EUDP for Dronninglund project were the points below. For each of these it is described how these have been reached in the project /4/.

1. To keep storage costs below 250 DKK/m<sup>3</sup> [3]
2. To produce heat at 350-400 DKK/MWh (5 % interest, 2 % inflation, 20 years annuity loan) [4]
3. To store excess heat for 200–250 DKK/MWh [5]

---

<sup>3</sup> Storage costs are 284 DKK/m<sup>3</sup> but since the objective of 250 DKK/m<sup>3</sup> is from 2008, a price increment of about 14 % is not much more than the cost development in the period.

<sup>4</sup> The heat production price for the new plant was expected to be as follows: Investment: 14,300,000 €, Capital costs (20 year loan, 3 % real interest): 949,500 €/year, Extra cost, operation: +21,100 €/year, **Total extra cost/year: 970,600 €/year**, Replaced energy production app. 16.300 MWh/year, Production price 59.5 €/MWh; This is prices without subsidies for Dronninglund. Future projects show the announced level of 350-400 DKK/MWh even despite inflation since 2008.

<sup>5</sup> The cost of the storage is 284 DKK/m<sup>3</sup> or 19.2 DKK/m<sup>3</sup>/year. Operation cost is approx. 100,000 DKK/year or 1.67 DKK/m<sup>3</sup>/year. Total 20.75 DKK/m<sup>3</sup>/year. The capacity of the storage is 0.085 MWh/m<sup>3</sup> and heat loss 0.027 MWh/m<sup>3</sup>. Therefore the storage cost will be 20.75 DKK/m<sup>3</sup>/(0.085-0.027) MWh/m<sup>3</sup> or 358 DKK/MWh with one storage cycle and 145 DKK/MWh with two storage cycles. The concept will become increasingly competitive in the event of increased prices for fossil fuels or a decrease in construction and running expenses for the concept. A simple payback time of 10 years will require a 30 % increase in the price of fuel or a similar decrease in construction costs. The most likely would however be a combination of increase in fuel prices and reduction of construction costs. Included in the above prices are normal contribution margins for the enterprises. During the first 3-5 years the combination of solar heating/long term heat storage/electricity regulation have only been established in few places in Denmark, as the planning period for this type of project is 2 years min. and because most CHPs will await the results of the first projects.

**Technical issues:**

*What have been major technical challenges / constraints regarding system design / construction?*

The ground water level in the old gravel pit is approx. 3 meters below the bottom of the storage and the soil consists of gravel and sand. This made the implementation easy mainly because rain and ground water did not cause problems. The excavation was ready after two months due to good conditions, and implementation of side and bottom liner took one month. In the middle of June 2013 the water filling could begin.

- The lid is following the water surface when it moves up and down during the year.
- The insulation in the lid is a closed cell polyethylene ("Nomalén" from company Termonova)
- Rain water on the lid is led to a pump well in the middle of the lid. The middle is lower than the edges because of weight pipes (HDPE-pipes with concrete inside) on the lower geo-membrane and the upper geo-membrane in the lid.

**Description about the design approach applied:**

*Which design targets have been set and why?*

The goal was to design a plant consisting of solar collectors, a pit heat storage and heat pumps. The goal is for the system to produce at least 50 % of the annual heat demand for heating cost not exceeding 400 DKK/MWh (typical calculation period: 20 years).

Beside from the financial statements above, the following design criteria were decided at the start of the design phase:

- Lifetime > 20 years
- Heat loss from cover: < 0.15 W/(m<sup>2</sup>·K) (corresponding to 300 mm mineral wool)
- Price level for actual size (10,000 m<sup>3</sup>): < 67 €/m<sup>3</sup>
- Price level for larger sizes (> 50,000 m<sup>3</sup>): < 30 €/m<sup>3</sup>
- No leakage

One of the commercial objectives in the projects was to store excess heat for 200-250 DKK/MWh.

*Which decision steps lead to the retained solution?*

1. 2005: Board of Dronninglund district heating decided on a strategy for future heat supply
2. 2007: Nordjyllands Vækstforum (forum for regional business) subsidizes pre-feasibility study for solar district heating project with high solar fraction of 50%
3. 2007: Application for funding "Sunstore 3" project at EUDP
4. 2008: Start of Sunstore 3 project
5. 2009: Technical concept finalized and detail engineering phase
6. 2012: Last approvals of project are given
7. 2013 – 2014: Construction phase (delayed from 2011)
8. May 2014: Inauguration

*Which tools have been used during the design phase?*

The software and simulation tool TRNSYS has been used in the design phase of the plant to find the optimal solution both in terms of energy production and the economic perspectives. This means that the model was supplied with several inputs of both economic details and energy performances.

The optimum of energy and economic performance have been found in the simulation tool TRNSYS where costs and energy in- and output have been used to optimize the specific parts of the plant in order to combine these in the most feasible way possible.

To find the optimal design a number of variations of some selected parameters were made in order to determine the share of renewables and heat price sensitivity to these. It was for instance seen that the renewable energy share increases with increasing collector area and that the economic



optimum (= the lowest heat price) was found between 35,000 m<sup>2</sup> and 40,000 m<sup>2</sup>, depending on which funding being used.

*What have been the main challenges in the design phase?*

The location of the pit storage was a challenge, since the first location of the heat store just north of Dronninglund was problematic due to soil and groundwater conditions (which would entail an estimated additional cost of almost 5 million DKK in ground work alone).

In relation to the grid in the solar field, a new discovery was found, since LOGSTOR has a fixed length of pipes for connecting the collector rows. In Dronninglund the distance between the collector rows was therefore found to 16 m / 3 = 5.33 m to fit the standard piping length. The municipality applied for an extension of the collector field of approx. 2,800 more m<sup>2</sup> of solar panels. The permission was given before implementation of the solar collectors.

*What have been the most crucial interfaces?*

The implementation process was delayed from summer 2011 to spring 2013 because of complaints from neighbors concerning the local plan procedure related to the location of the pit storage. It has shown to be important to start the dialogue with both the municipality (regional authority) and the local citizens at an early stage.

The project group decided in consultation with Brønderslev Municipality's Planning Department to move the heat storage into an old gravel pit west of Dronninglund, where there were no problems with groundwater. At this location the solar plant and the central is placed without conflict with planning interests (including edge of forest, monuments etc.)

#### **4.1.4 Lessons learned (barriers and success factors)**

*What have been major success factors?*

A great success factor of the project in Dronninglund is that the concept contributes to realization of Danish energy policy objectives, because it makes it possible to extend the solar fraction in district heating production.

This is seen through several other district heating utilities that now are investigating pit heat storage and solar solutions in future master plans. Some have already been implemented:

- Vojens District Heating has implemented approximately 200,000 m<sup>3</sup> pit heat storage combined with 70,000 m<sup>2</sup> solar collectors.
- Gram District Heating has implemented approximately 122,000 m<sup>3</sup> pit heat storage combined with 44,000 m<sup>2</sup> solar collectors.

Besides that, the marked for pit heat storages is expected to be extended since the storage could also be relevant in systems with waste incineration plants and CHP plants with surplus heat production in the summer period. Some development in the HDPE is still needed when storage at high temperatures (> 90 °C) are needed.

*What have been major bottlenecks?*

If an electrical driven heat pump is part of the energy system it contributes by offering electricity consumption in periods with cheap export prices (power to heat).

The electrical heat pump was due to Danish electric taxes one of the bottlenecks in the financial part of the project. The electrical heat pump was therefore replaced by an absorption heat pump.

*What are the major lessons learned? /5/*

Several lessons learned from the project can be used in similar systems in the future:

Issues with reduced capacity of the heat exchanger between solar plant and storage due to dirt in the water and corrosion (probably galvanic and bacterial) in in- and outlet pipes in the storage in the Marstal project were taken into account in Dronninglund where in- and outlet pipes are in stainless

steel, but even then corrosion can occur. Therefore a corrosion expert was consulted and the following precautions were taken against corrosion and to protect the heat exchangers:

- Pipes between solar thermal collector field, seasonal storage and Søndervang (location of heat pump) were cleaned before water was filled in
- Filters were installed to protect the heat exchangers
- In the commissioning phase special attention was paid to (heating) water treatment:
  - o Salts (especially chlorides) were removed with reverse osmosis
  - o As much oxygen as possible was mechanically removed
  - o pH-value of the water was raised to 9.6-9.8 with additives
- During operation the water in the storage is going to be analyzed for content of oxygen, salts, bacteria and pH-value at least annually

#### 4.1.5 Summary

At the time the plant was constructed, it was the largest solar DH plant in the world. The project was innovative because the large solar seasonal storage and heat pump in combination with a CHP plant, which at the time of construction was not seen before. This meant additional challenges, since the CHP and solar heat production has to be scheduled for the daily operation. In return, solar heating, seasonal storage and heat pumps makes the CHP plant a more flexible player at the electricity market, thus facilitating the integration of more fluctuating electricity in the overall energy system.

There is seen a range of advantages in relation to the solar DH plant:

- Solar district heating has the potential to significantly reduce the carbon footprint of conventional district heat supply.
- Increase the flexibility of the plant's role at the electricity market by releasing the engines at CHP plants from forced heat production when it is not feasible. This can help stabilising the electricity grid while integrating more RE (e.g. from wind turbines).
- Security of supply: The delivery of solar heating is safe and there will be no rationing or problems with the delivery of the energy source used for heat production.
- Solar thermal can produce more than 20 times as much heat on one hectare compared to an area used for growing biomass for boilers.
- Stable heat production price from solar DH (only capital costs and minor maintenance and pumping costs).

Due to these reasons, more and more utilities look towards introducing solar heat or increasing the share of solar heat they already have.

## 4.2 Hybrid solar district heating in the city of Taars, DK

### Authors:

Bengt PERERS	Technical University of Denmark, DK	<a href="mailto:beper@byg.dtu.dk">beper@byg.dtu.dk</a>
Simon FURBO	Technical University of Denmark, DK	<a href="mailto:sf@byg.dtu.dk">sf@byg.dtu.dk</a>
Zhiyong TIAN	Technical University of Denmark, DK	<a href="mailto:zhiytia@byg.dtu.dk">zhiytia@byg.dtu.dk</a>
Andreas ZOURELLIS	Aalborg CSP, DK	<a href="mailto:azo@aalborgcsp.com">azo@aalborgcsp.com</a>

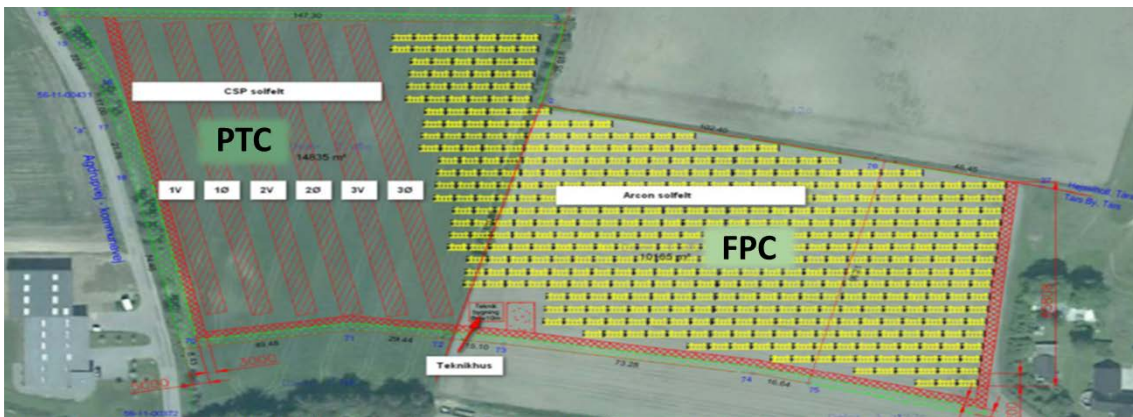

**Figure 6: Aerial view on the hybrid solar district heating system in the city of Taars** (Source: Aalborg CSP). In sum, 5,960 m<sup>2</sup> flat plate collectors (FPC) and 4,039 m<sup>2</sup> parabolic through collectors (PTC) are hydraulically connected to the local DH network. In the period 09/2015-08/2016 solar thermal provides a share of 22 % of the entire district heating output of the utility.

**Project fact box:****General information:**

Location: **City in Northern Denmark (Jutland), Hjørring Municipality**

Urban scale of area: **~1km \*1km = 100 [ha]**

Population in the area: **1,895**

Building mix in the area: **Mainly single-family homes, few multi-storey buildings**

Plant owner: **Consumer-owned cooperative with limited liability (Taars Varmeværk A.m.b.A)**

**Specific information about Taars Varmeværk A.m.b.A:**

Heated (gross) floor area (supplied by district heating): **126,000 m<sup>2</sup> (2015/16)**

Final thermal energy consumption (heat generated, incl. thermal losses): **18,583 MWh (2015/16)**

Useful thermal energy consumption (heat sold): **14.189 MWh (2015/16)**

Network heat losses: **4,394 MWh/a (23.6 %)**

Heating grid trench length: **13 km (service pipes not included)**

No. of building substations: **approx. 850**

Supply/Return temperature levels: **Supply 68-78°C, return 38°C**

(Thermal) energy supply technologies: **N-Gas CHP (5.2 MW<sub>th</sub>/5.0 MW<sub>el</sub>), 2 N-Gas boilers (6.0 and 2.9 MW<sub>th</sub>), solar thermal (6.7 MW<sub>p,th</sub>)**

**Specific information about the solar thermal part:**

Solar thermal collector area: **10,000 m<sup>2</sup><sub>aperture</sub>**

**Flat plate collector (FPC) field: 6,419 m<sup>2</sup><sub>gross</sub> / 5,960 m<sup>2</sup><sub>aperture</sub> (473 panels)**

**Parabolic through collector (PTC) field: 4,040 m<sup>2</sup><sub>aperture</sub> (60 modules)**

Thermal energy storage: **Two (unpressurized) storage tanks with a total of 2,430 m<sup>3</sup>**

Annual solar energy yield: **4,060 MWh (FPC: 2,650 MWh, PTC: 1,410 MWh) (2015/16)**

Solar fraction: **22% (based on heat generated resp. final DH output)**

Specific annual solar energy yield: **406 kWh/ (m<sup>2</sup><sub>aperture</sub>·a), (measured 09/2015-08/2016)**

**Economics of the solar thermal part:**

Total project cost: **3.5 M EUR (excl. VAT); grant/funding (excl. VAT): 0.4 M EUR (11.3%)**

<i>FPC collector field incl. foundations</i>	<b>42 %</b>
<i>PTC collector field incl. foundations</i>	<b>34 %</b>
<i>Solar energy storage tanks incl. foundation</i>	<b>0 % (existing)</b>
<i>DH pipes, pumps, heat exchangers, control, etc.</i>	<b>15 %</b>
<i>Land, ground work</i>	<b>5 %</b>
<i>Consulting / engineering</i>	<b>4 %</b>

### 4.2.1 Introduction and description

#### History of Taars district heating

Taars Varmeværk A.m.b.A is situated in Northern Denmark (Jutland, Hjørring Municipality) and was established in 1960 as a consumer-owned cooperative with limited liability. Heat generation was first based on heavy fuel oil boilers which were replaced by two N-Gas boilers with 6.0 resp. 2.9 MW<sub>th</sub> as well as an N-Gas CHP with 5.2 MW<sub>th</sub> / 5.0 MW<sub>el</sub> in the early 1990s. Additionally, two non-pressurized thermal energy storage tanks with a water volume of 2,430 m<sup>3</sup> each for load balancing and optimized CHP operation according to electricity prices were installed at that time.

In 2014 the board of Taars Varmeværk A.m.b.A decided to substitute a significant share of natural gas for district heating by solar thermal. The idea for a hybrid solar district heating system combining concentrating and non-concentrating solar thermal collector technologies was born in talks together with the Danish turn-key concentrating solar thermal system provider Aalborg CSP. The new Taars hybrid solar district heating system finally was commissioned in July 2015 (see hydraulic scheme in Figure 7). By end of 2016, the district heating utility supplies around 850 consumers via 13 km of district heating network. In the period 09/2015-08/2016 solar thermal provides a share of 22% of the entire district heating output of the utility.

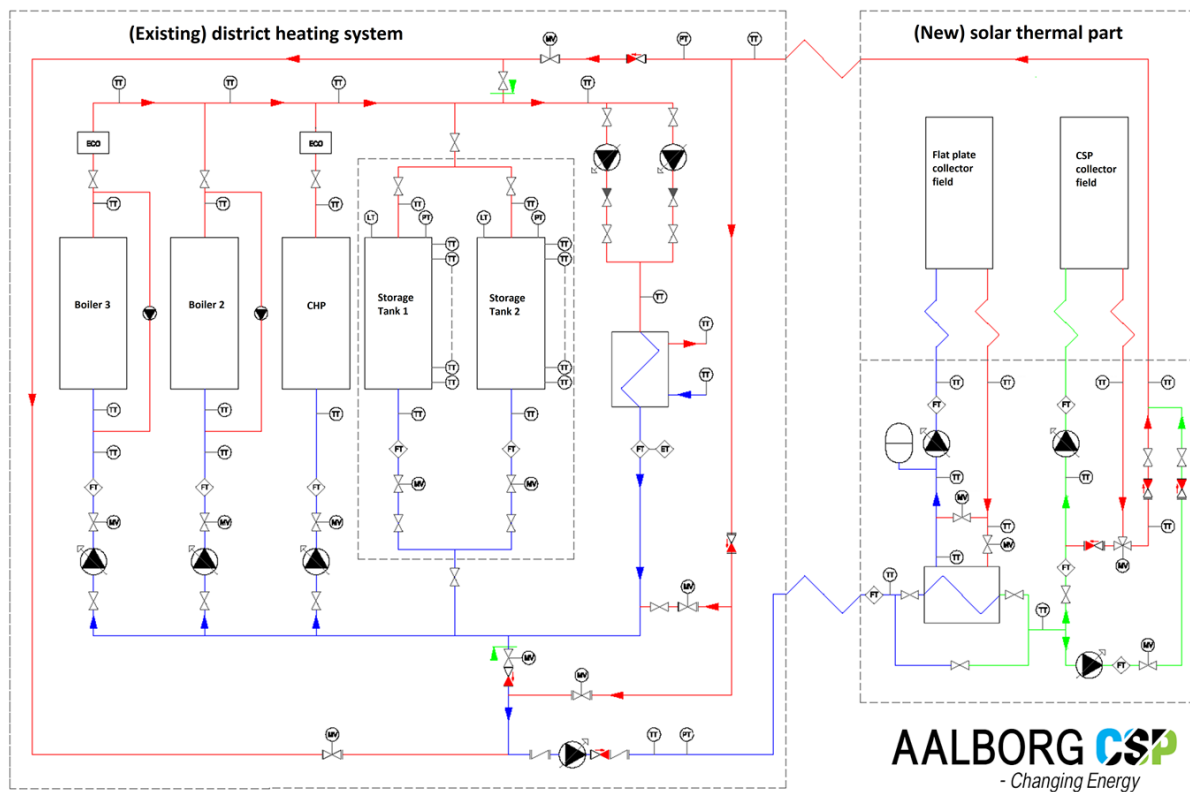

Figure 7: Taars District heating schematic diagram including new hybrid solar thermal collector field (Source: Aalborg CSP)

### 4.2.2 Technical description of the concept and innovative approaches

#### Working principle of the hybrid solar district heating concept

The Taars hybrid solar district heating system is the first project around the world, where a combination of concentrating parabolic through collectors (PTC) and non-concentrating flat plate collectors (FPC) is hydraulically connected to a district heating network. The idea behind is to first use the FP collectors at lower temperatures to preheat the district heating return flow (from around 40°C



up to 70°C) and boost the temperature up to 95°C with the PT collectors afterwards (see schematic diagram in Figure 8).

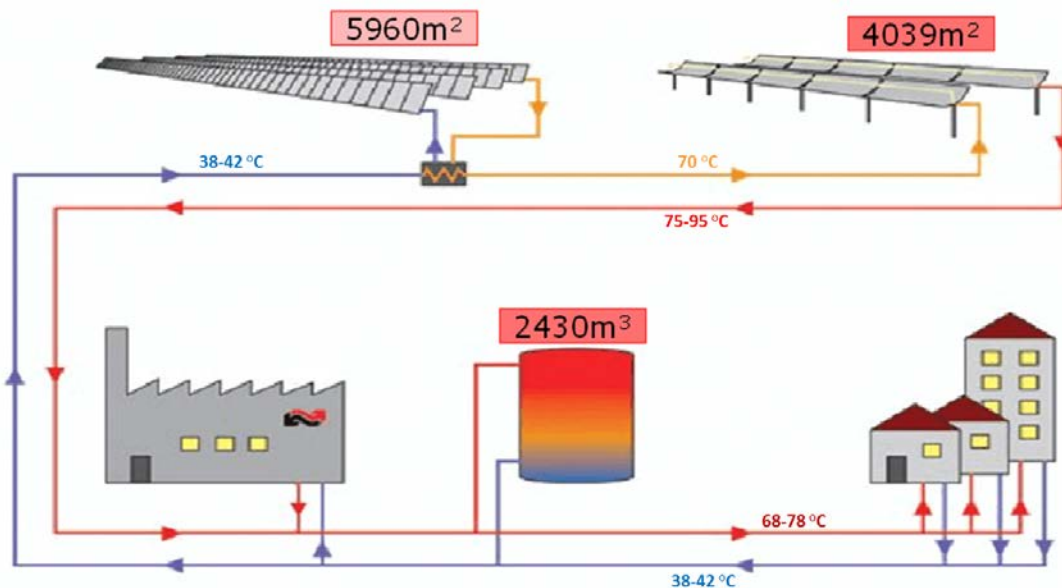

**Figure 8: Principle diagram of the Taars hybrid solar district heating system** (Source: Aalborg CSP)

In detail, the flat plate collector field consists of two different kinds of collectors from Danish company Arcon-Sunmark A/S – first half of the field is equipped with collectors optimized for lower temperatures ( $HT_{HEATboost}$  35/10) and second half is equipped with advanced flat plate collectors with reduced thermal (convection) losses ( $HT_{HEATstore}$  35/10) for higher temperatures (in case of Taars up to around 70°C). For even higher output temperatures of up to 95°C the parabolic through collector field is serial connected to the flat plate collector field. Parabolic through collectors were delivered by Danish company Aalborg CSP.

Combining the different solar thermal technologies has several advantages: First, each collector type is operated at temperature levels where highest efficiencies are possible (FPC are more efficient at lower temperatures than PTC). Second, the entire system may be actively prevented from overheating / stagnation by means of defocussing the parabolic throughs from the sun [6] and third, the daily solar thermal production profile may be evened out due to different solar thermal collector orientation (FPC are south oriented and hence produce most at noon whereas PTC are tracked from east to west for higher gains before and after noon).

For freeze protection, the flat plate collector loop is filled with a water-glycol mixture (40%). By contrast, in the parabolic through collector field only district heating water is filled (and hence no glycol, glycol pump, control valves, expansion tank, glycol loop control and heat exchangers are needed here). In order to avoid freezing, district heating return water is circulated in the PTC loop if the outdoor temperature drops close to, or below the freezing point. Due to the highly efficient insulation of the PTC vacuum tube absorbers (working principle of a thermos flask) very little energy for freeze protection is needed (measurements by DTU [5] showed, that freeze protection amounts to around 1% of annual PTC output which is comparable to performance losses in a flat plate collector field caused by the water/glycol mixture with additional heat exchanger).

<sup>6</sup> See IEA SHC Task 49 technical report A.1.2. on Overheating prevention and stagnation handling in solar process heat applications for further information regarding the phenomenon of stagnation in solar thermal applications and strategies for its handling.

### 4.2.3 Decision and design process

*The following questions and answers aim at understanding the context (political, urban, energy) and the pre-design steps that led to the retained solution.*

#### **General / organizational issues:**

*Why was this project initiated, to answer which need?*

District heating is the most common heating technology in the Danish residential sector. However, the majority of district heating systems installed today are equipped with N-gas based CHP engines and economy of those systems got significantly reduced in the past years as electricity prices, especially in summer, decrease constantly. For the board of Taars district heating this was a major reason to react and to look for possibilities to reduce its N-gas consumption. Solar thermal was chosen to be an appropriate technology option because it is a mature and proven technology in Denmark concerning cost performance, reliability and life time.

*Which stakeholders were involved in the project?*

- District heating utility: Taars Varmeværk A.m.b.A
- Local authority: Hjørring municipality (Role: approval of project)
- Main Entrepreneur: Aalborg CSP A/S
- Technical consultants: JPH Rådgivning
- Other
  - o Flat plate collector supplier: Arcon Solar A/S
  - o Parabolic through collector supplier: Aalborg CSP A/S
  - o Pipe supplier: Isoplus A/S
  - o 3<sup>rd</sup> party: Technical University of Denmark (DTU)

*Who (what) were drivers and who (what) were opponents (barriers) – and why?*

Major driver for the investment in the new solar thermal system was the lower cost per kWh for the district heating customers compared to the existing (N-gas based) system.

One reasons to go for the hybrid system was increased security of operation due to automated stagnation management (in situations where solar production may exceed heat demand and storage capacity, boiling of the system is simply avoided by defocussing the parabolic through collectors). In addition, outlet temperature from the PTC field may be controlled very accurately.

By contrast, barriers to overcome were linked to lacking experience and hence lacking confidence with parabolic through collector technology.

*What have been the main challenges regarding decision finding?*

The PTC technology was new and less proven than flat plate collector fields.

*What was finally the crucial parameter for go /no-go decision?*

Lower cost per kWh of district heat for the final customer compared to the existing system (calculated over system life-time).

#### **Financing issues:**

*What have been the main challenges / constraints regarding financing?*

The “bankability” (to get loans) of a solar heating plant has been a major challenge in Denmark as well in the past. The situation improved significantly due to the large number of well performing, robust and reliable solar district heating applications installed today.

In Taars, “bankability” was not an issue. However, it was required to prove in calculations / simulations that the economic performance of the new district heating concept is better than the existing one.



*Which business model applies to the project?*

The turn-key solar thermal system was sold to the local district heating company (which is owned by the local DH customers). A more stable, reduced long term cost of district heating energy for the final customers/owners was offered.

**Technical issues:***What have been major technical challenges / constraints regarding system design / construction?*

- The control strategy of serial connected collector fields for different collector technologies, hydraulic design and orientation
- Optimum charging strategy of the existing energy storage tanks in order to utilize solar thermal output best (especially high temperatures from the PTC). There is still potential for improvements in this regard and optimization is on-going here.

**Description about the design approach applied:***Which design targets have been set and why?*

The utility wanted to substitute around 30% of its natural gas consumption with solar thermal which is a high value for a system with short-term (diurnal) storages only (typical solar fractions in Danish SDH systems with diurnal storage range from 5-20%). However, this target was achieved by means of slightly oversizing the system. In times of surplus production (summer) the parabolic through collectors are simply defocussed.

Second design target was to achieve lower levelized cost of heat with the new system compared to the existing system (N-Gas boiler + CHP).

*Which decision steps lead to the retained solution?*

Despite a series of publications /1/, /3/, /4/ and promising pilot experiments /2/ confirmed competitive thermal performance of PTC in Danish climate, the technology seemed to be too unproven for Taars district heating at first. Finally, the combination with FPC turned out to be an attractive compromise with positive synergies for solar thermal system operation and performance. Moreover, it could be shown in simulations that the new system with solar thermal is competitive with the existing N-gas based system in terms of levelized cost per kWh of heat. Especially the latter was decisive for the investment in this solar thermal solution by the DH utility.

*Which tools have been used during the design phase?*

For the design and energy calculations of the PTC Aalborg CSP used a company-internal tool based on MS Excel.

The techno-economic performance of the entire system (solar thermal systems including storage) was analyzed and optimized applying an adapted TRNSYS-GenOpt model. The calculations showed that there was a positive synergy in combining PTC and FPC collectors: Although the present cost per m<sup>2</sup> of PTC is higher than for FPC, the total energy cost is reduced by installing both technologies considering positive synergies as already explained. The TRNSYS-GenOpt model is based on individually validated component models and empirical collector parameters. Meanwhile, the simulation model has been validated with annual measured data from the plant /5/. The experience of the Taars solar heating plant can be used to develop and optimize new large solar heating plants.

*What have been the main challenges in the design phase?*

- Mix of different (concentrating and non-concentrating) solar collector technologies
- The lack of measured DNI (direct normal irradiation) data in Denmark (PTC can only convert direct irradiation and hence this information is crucial for both system design and system operation strategies).

*What have been the most crucial interfaces?*

The cooperation between the two turn-key solar thermal collector companies (FPC and PTC) showed potentials and synergies on the one hand side but on the other hand side the two companies are competitors, especially on the Danish market, which makes communication processes difficult.

#### 4.2.4 Lessons learned (barriers and success factors)

*What have been major success factors?*

- Professional planning, design and construction of the system
- High competence with solar thermal and hydraulic system design of the involved companies
- The DH users invest in the solar plant themselves (principle of a consumer-based co-operative) which shows that solar thermal is a trusted and highly accepted technology

*What have been major bottlenecks?*

- Extreme weather during the plant construction in winter was challenging for punctual delivery of the project. However, the project was delivered on the agreed time schedule.
- The customer was unfamiliar with the PTC technology.

*What are the major lessons learned?*

The combination of parabolic through collectors and flat plate collectors connected in series, gives a positive synergy for the whole system performance and cost due to:

- Better overall economy and operational advantages by more even energy production over the day (PTC produce more heat in the morning and evening while FPC peak at midday)
- Built in overheat protection by defocusing the PTC collectors
- The tracking axis direction/azimuth can be adjusted quite freely from due North-South, to even out the daily profile with only minor loss in annual performance.

The plant operator needs special education to utilize the PTC high temperature possibilities best (e.g. in order to increase storage capacity the energy storage tanks may be charged with higher temperature heat from the PTC collector field than used to).

The design of the solar thermal system size targeting 30% solar fraction was proven to work as expected. In the first year of operation a solar fraction of 26% (referring to entire district heating production) resp. 28.6% (referring to heat sold) was achieved. This high solar fraction is reached by efficiently using the existing energy storage tanks only (no new storage capacity was installed). To achieve these high solar fractions without additional energy storage capacity built, the solar thermal system is slightly oversized. As a consequence, surplus production in summer is avoided by defocussing the PTC from time to time [7].

#### 4.2.5 Summary

Modern parabolic through collectors with vacuum tube absorbers perform excellent also at high latitude locations like in Denmark. As an added value for district heating operators PTC technology increases operation safety because overheating/stagnation may be effectively avoided by defocussing the mirrors from the sun. With the overheating/stagnation problem solved, solar thermal systems can be designed for higher solar fractions (in case of Taars: 30%) without installing additional solar energy storage capacity (in Taars existing diurnal storages for load balancing are used as solar energy storages). Another advantage linked to PTC technology is that the tracking axis may be easily adapted over the day and also in the course of the year. In combination with flat plate collectors this enables a more even solar output in the course of a day which makes it easier for the boilers / CHP unit to react and saves cost in equipment due to reduced peak loads.

---

<sup>7</sup> A detailed analysis of the solar thermal system operation and performance (including monitoring data from one year of operation) was done by DTU and is documented in /5/.

### 4.3 Solar-assisted urban quarter “Salzburg-Lehen”, AT

Norbert DORFINGER	Salzburg AG für Energie, Verkehr und Telekommunikation	<a href="mailto:norbert.dorfinger@salzburg-ag.at">norbert.dorfinger@salzburg-ag.at</a>
Inge STRASSL	SIR - Salzburg Institute for Regional Planning and Housing	<a href="mailto:inge.strassl@salzburg.gv.at">inge.strassl@salzburg.gv.at</a>
Franz MAUTHNER	AEE - Institute for Sustainable Technologies	<a href="mailto:f.mauthner@aee.at">f.mauthner@aee.at</a>



**Figure 9: Aerial view on Northern part of the urban quarter “Stadtwerk Lehen”** (Source: top: AEE INTEC, bottom: Fotohof). In sum, 2,048 m<sup>2</sup> solar thermal collectors are split into 13 roof-mounted collector fields and roughly supply 25% of the final thermal energy demand (incl. network heat losses) of the buildings with a heated floor area of 48,860 m<sup>2</sup>.

**Project fact box:****General information:**

Location: Salzburg district of „Lehen“, Austria

Urban scale of area: 42,000 m<sup>2</sup>

Population in the area: N/A

Building mix in the area (kind of building category in % of heated floor area):

19,000 m <sup>2</sup> of laboratory, ordination and office space	(38.9%)
20,620 m <sup>2</sup> of subsidized housing	(42.2%)
3,030 m <sup>2</sup> student residence	(6.2%)
1,000 m <sup>2</sup> cultural and social facilities	(2.0%)
5,000 m <sup>2</sup> shops and other housing	(10.2%)

Heat consumer characteristics in the area: 100 % medium size consumers (80-800 MWh/a)

Plant owner: public

**Specific information:**

Heated (gross) floor area: approx. 48.860 m<sup>2</sup>

Final thermal energy consumption (incl. network heat losses): 3,975 MWh (measured, 2013/14)

Useful building thermal energy consumption (heat sold): 3.575 MWh (measured, 2013/14)

Network heat losses: approx. 400 MWh/a (10%)

Heating grid trench length: 680 m

No. of building substations: 20

Supply/Return temperature levels: 65/35 °C (designed); 65/35-45 °C (measured)

(Thermal) energy supply technologies: District heating (1.8 MW<sub>th</sub>), Solar thermal (1.3 MW<sub>p,th</sub>), Compression heat pump (160kW<sub>th</sub>)

**Specific information about the solar thermal part:**

Solar thermal collector area: 2,048 m<sup>2</sup><sub>gross</sub> / 1,855 m<sup>2</sup><sub>aperture</sub>

Thermal energy storage: 200,000 liters (pressurized steel tank)

Annual solar energy yield: 989 MWh (measured, 2013/14)

Solar fraction: 25% (based on final thermal energy consumption)

Specific annual solar energy yield: 533 [kWh/(m<sup>2</sup><sub>aperture</sub>·a)] (measured, 2013/14)

**Economics figures:**

Total building project: ~ 42 M EUR (excl. VAT) / ≈ 2.3 M EUR subsidies from EU

Solar heating system: ~ 0.9 M EUR (excl. VAT) / ≈ 0.4 M EUR subsidies from government



### 4.3.1 Introduction and description

#### Urban quarter Stadtwerk Lehen

From 2011 to 2016, a new residential area with a total of 287 dwellings in nine buildings as well as a student dormitory and a kindergarten was built in the Salzburg district of „Lehen” (Figure 10, yellow and green area). The two- to eight-storey buildings were designed to meet lowest energy building standards ( $4\text{--}18\text{ kWh/m}^2_{\text{GFA/a}}$ ) and are equipped with air ventilation including heat recovery. Moreover, in the Southern part of the quarter several new low-energy buildings for commercial use (laboratory, ordination and office space as well as shops and social facilities) were erected and an existing 10-storey office building was renovated (Figure 10, red area). In sum, the area comprises a gross floor area of approx.  $48,650\text{ m}^2$ .

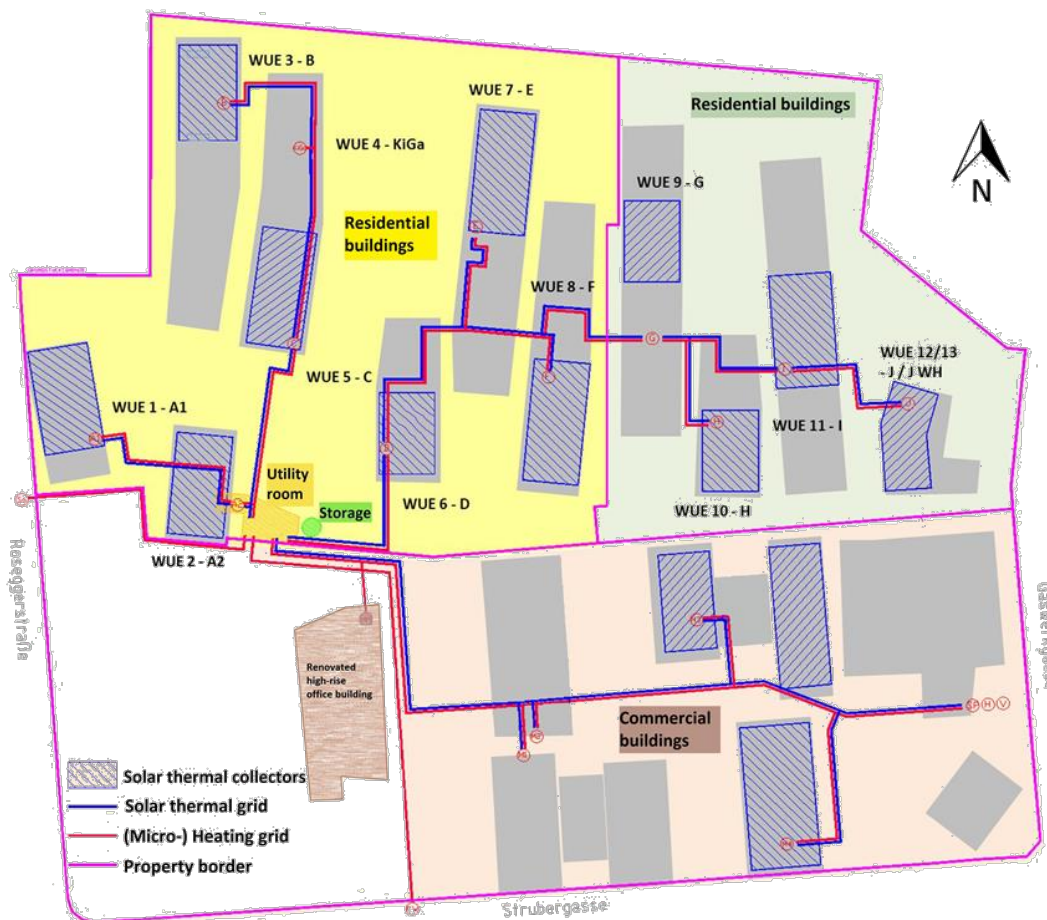

**Figure 10: Site plan Stadtwerk Lehen** (Source: adapted from EGS-plan). North: new built housing area; South: new built commercial area and renovated high-rise office building.

#### Heat supply

For the supply with thermal energy all buildings are connected to a low-temperature (65/35) heating grid (micro-grid) that serves a 2-pipe building distribution network with local heat transfer stations for space heating and domestic hot water preparation. The annual consumption of thermal energy (final energy including transmission losses) was measured to be  $3,975\text{ MWh}$  in the period Aug13-Jul14.

Roughly one quarter of the thermal energy for the supply of the buildings is provided by a solar thermal system. Therefore,  $2,048\text{ m}^2_{\text{gross}}$  ( $1,855\text{ m}^2_{\text{aperture}}$ ) flat plate collectors ( $1.3\text{ MW}_{\text{th,p}}$ ) split into 13 separate collector fields are installed on building flat roofs (Figure 10) and feed into a  $200\text{ m}^3$  central thermal energy storage (Figure 11).

Additionally, a compression heat pump with a heating capacity of  $160 \text{ kW}_{\text{th}}$  is hydraulically connected to the energy storage utilizing the lower storage part as heat source while charging the upper storage part.

Heat pump operation enables temperatures down to  $10^\circ\text{C}$  in the lower part of the energy storage which has several positive effects on the entire system efficiency: On the one hand, storage capacity is increased meaning that with similar storage volume more energy can be stored (higher  $\Delta T$ ). Second, average storage temperature is decreased which decreases thermal energy storage losses and third, efficiency of the solar thermal collectors is increased due to lower operating temperatures. District heating serves as auxiliary heating system and backup (Figure 12).



Figure 11:  $200 \text{ m}^3$  energy storage tank  
(Source: Fotohof)

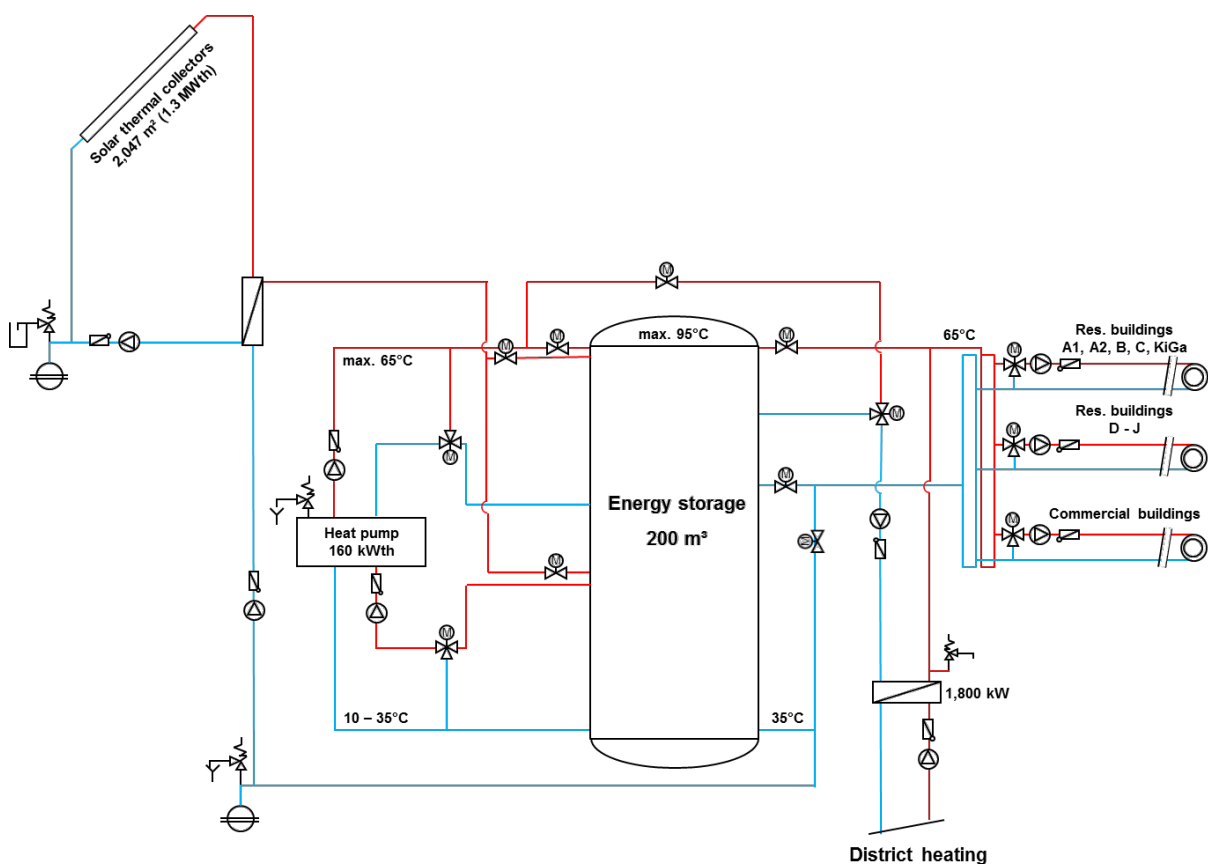

Figure 12: Hydraulic scheme of the heat supply system Stadtwerk Lehen (Source: AEE INTEC)

#### 4.3.2 Technical description of the concept and innovative approaches

The heat supply concept for the new urban quarter was part of an integrated urban planning process. From the very beginning, focus was given to both high energy efficiency and low-carbon energy supply. The decision finding process ended up in the prioritization of a low-temperature ( $65/35^\circ\text{C}$ )

heat supply and distribution system with a high share (>25%) of solar thermal energy in the heat supply. As city district heating is attached close to the new urban quarter it was also decided to use this energy source as auxiliary system. With this basic technical boundaries decided it was possible to design the heat supply and distribution system in detail from conversion to end-user stage and very notably, to identify and occupy space for installing the solar thermal collectors as well as the energy storage tank in an early project stage.

In a later optimization step in the design phase it was decided to hydraulically attach a compression heat pump to the energy storage tank in order to increase storage capacity (and hence reduce its size) and solar thermal efficiency.

The concept was finally realized and proven to work satisfying in the framework of a scientific monitoring program: On the one hand side solar energy yields could be significantly increased due to heat pump operation at hours with low solar irradiation. In the period Aug13-Jul14 specific annual yield of  $533 \text{ kWh}/(\text{m}^2_{\text{aperture}} \cdot \text{a})$  was measured which was 25% higher than projected. On the other hand specific storage volume could be kept relatively low (100 liter per  $\text{m}^2$  collector area installed) compared to the solar fraction achieved (25%). Seasonal performance factor of the heat pump was always between four and five.

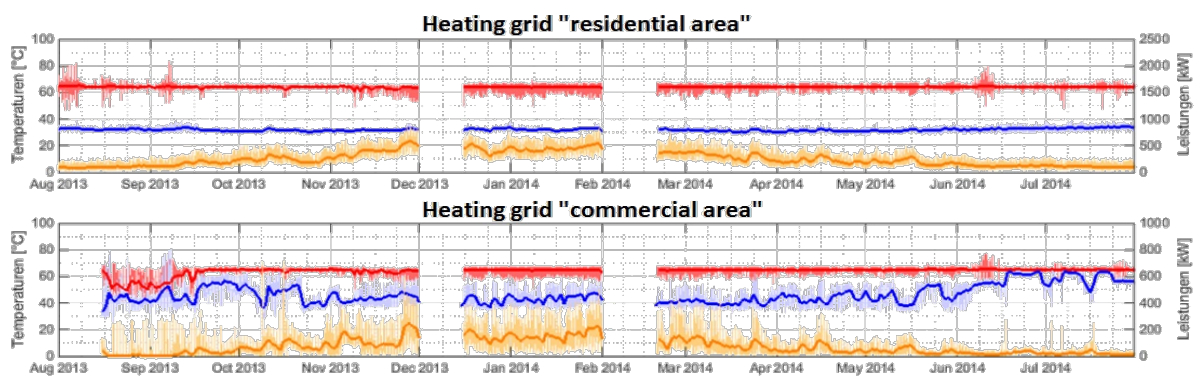

**Figure 13: Measured micro-grid supply (red lines) and return (blue lines) temperatures as well as capacities (yellow lines) in the Northern (residential area) resp. Southern (commercial area) part of the supply area (Source: AEE INTEC)**

Sensitive parameters of the entire technical concept especially refer to the supply and return temperatures in the micro-grid (Figure 13). While the design temperatures of 65/35°C could be well achieved in the Northern part of the quarter (residential buildings) higher return temperatures of 40-45°C were measured in the Southern part (commercial and retrofitted buildings). Since all temperatures are mixed again in the energy storage this should be avoided, e.g. by proper hydraulic balancing.



### 4.3.3 Decision and design process

*The following questions and answers aim at understanding the context (political, urban, energy) and the pre-design steps that led to the retained solution.*

#### **General / organizational issues:**

*Why was this project initiated, to answer which need?*

Large fallow area in the city center was decided to become revived by means of a new residential and commercial area. The idea for a solar-assisted micro-heating grid in close distance to an existing district heating supply area evolved due to the availability of promotion schemes for solar thermal in combination with newly constructed buildings (in Salzburg, housing subsidies incentivize the implementation of renewable technologies).

*Which stakeholders were involved in the project?*

- Non-profit real estate developers (GSWB and Heimat Österreich)
- Commercial real estate developer (Prisma)
- Regional Multi Utility Company (Salzburg AG für Energie, Verkehr und Telekommunikation)
- Several city council departments (a.o. town planning, residential building research)
- Salzburg Institute for Regional Planning and Housing (SIR)

*Which resources were available before the project?*

- Strong participation and intervention by local administrative facilities and overall good co-operation between involved actors
- Dedicated individuals with high specific expertise

*Who (what) were drivers and who (what) were opponents (barriers) – and why?*

On the one hand several important stakeholders joined forces in order to come up with a commonly accepted solution. On the other hand subsidies have been enablers for innovative approaches and investments, specific research and monitoring (EU funding from the Concerto initiative, national R&D funding, housing subsidy scheme of the state Salzburg).

Barriers to overcome have been high initial investment costs (compared to standard solutions) as well as time-consuming and partly complicated modalities linked to the subsidy schemes.

*What have been the main challenges regarding decision finding?*

Contracting (especially handling of risks linked to pre-financing, accounting, property limits, operation management, funding allocation)

*What was finally the crucial parameter for go /no-go decision?*

A **quality agreement** signed by all involved parties as well as the signed Concerto project contract made decisions transparent and binding.

#### **Financing issues:**

*What have been the main challenges / constraints regarding financing?*

- Contracting among the partners
- Implementation of technical innovations within the cost ceilings in building construction

*Which business model applies to the project?*

- *“Wärme-Direkt-Service”*: Heat customers are supplied with heat including service and operation of the whole distribution system (including installation in the flat) for a basic rate per m<sup>2</sup> useful area plus an energy rate per kWh.

#### **Technical issues:**

*What have been major technical challenges / constraints regarding system design?*

- Allocation of appropriate roof areas as well as architectural implementation of the large distributed solar thermal collector fields
- Interface roof (erection of the solar thermal collector fields by the energy supplier on the roofs of the buildings owned by the real estate developers)
- Hydraulic set-up, control and operation of the storage-integrated compression heat pump

**Description about the design approach applied:***Which design targets have been set and why?*

Superior target was to design and implement a highly energy efficiency and low-carbon energy heat supply for the new urban quarter Stadtwerk Lehen. More specifically, it was decided to implement a solar-assisted micro-heating grid in close distance to the existing district heating supply area which should meet optimum cost-performance targets (and hence should result in lowest possible cost of heat for the future residents).

*Which decision steps lead to the retained solution?*

1. Idea for a solar-assisted low-temperature micro-heating grid backed up by district heating and with storage integrated heat pump was brought in by a technical consultant
2. Consensus amongst all stakeholders regarding the technical concept was obtained
3. Quality parameters and criteria for the project were defined and added to the quality agreement document
4. Applications for subsidies on investment for innovative technologies, project-specific R&D as well as monitoring were handed in (EU Concerto initiative, national R&D promotion scheme, Salzburg state subsidies scheme on housing developments)
5. Establishment of a control group in which the essential decisions and information are communicated and reconciled on a monthly basis
6. Accompanying quality assurance on the basis of the quality agreement and the EU contract (SIR)
7. Technical simulations, scientific accompaniment and monitoring by external scientific partner (Steinbeis Institute, Germany)
8. Further engagement and interventions by the City of Salzburg as well as by the multi utility company(Salzburg AG) to expand the project area to the adjoining renovation area

*Which tools have been used during the design phase?*

- Simulation tools of the energy consultants and scientific partners
- control group meetings
- quality agreement combined with quality assurance measures

*What have been the main challenges in the design phase?*

- To identify and bring together all necessary stakeholders and actors
- Communication and decision-making processes

*What have been the most crucial interfaces?*

- utility ⇔ real estate developer
- real estate developers ⇔ politics
- A coordinator was appointed by the city of Salzburg (secretary of the planning town council)
- Accompanying quality assurance by SIR ⇔ EU project

**4.3.4 Lessons learned (barriers and success factors)***What have been major success factors?*

- Setting up a quality agreement
- EU project with liabilities
- The common will
- Common tender
- Good communication amongst stakeholders and implementation of a control group

*What have been major bottlenecks?*

- Financing (pre-financing with uncertainties) and Contracting
  - o Contracts were necessary before tendering which led to
  - o Tough contractual negotiations
- The interface roof (who is to blame for leaks...)

*What are the major lessons learned?*

- Clear targets at the beginning and a moderated process with quality assurance and clear responsibilities are prerequisites
- Political will and support are very conducive
- Reconciliation Interface Roof → Construction of the collectors, if possible by the real estate developers themselves (liability questions...)

#### 4.3.5 Summary

The case of **Stadtwerk Lehen** is a very successful example of an integrated urban planning process with many involved stakeholders who agreed upon an efficient and low-carbon energy supply system. Based on a superior target (high efficiency, high share of RES, district heat as auxiliary service) the design of the heat supply system was matched to the design of the new and renovated buildings and vice versa in a very early project stage. This approach favors holistic urban planning and leads to optimal energy system designs.

**From a technical point of view**, the realized technical concept was proven to work very satisfying. Low temperatures in the heating grid together with heat pump operation enabled above-average solar energy yields and high solar fractions. Meanwhile three more similar systems with storage-integrated heat pumps were built in social housing projects in Salzburg based on the “Stadtwerk Lehen” best-practice example.

**From an organizational point of view** the challenge was to reach consensus between various stakeholders with quite different background and responsibilities. In this respect, a coordinated, moderated and in a later stage contractually binding procedure with accompanying quality assurance was proofed to be a successful approach for this project. Moreover, applying for subsidies and participation in R&D projects (European, national and state initiatives) helped to deeply analyze and proof innovative (out-of-the-box) ideas, to co-finance new technologies and to disseminate achievements to a broader audience.

#### 4.4 Solar-assisted urban quarter “Freiburg-Gutleutmatten”, DE

##### Authors:

Sebastian Herkel	Fraunhofer ISE, DE	sebastian.herkel@ise.fraunhofer.de
Mehmet Elci	Fraunhofer ISE, DE	mehmet.elci@ise.fraunhofer.de
Axel Oliva	Fraunhofer ISE, DE	axel.oliva@ise.fraunhofer.de
Alexander Ripka	badenovaWÄRMEPLUS GmbH & Co. KG, DE	alexander.ripka@badenova.de



**Figure 14: View on Eastern part of the urban quarter “Gutleutmatten”** (Source: Fraunhofer ISE). In sum, 2,220 m<sup>2</sup> solar thermal collectors are split into 38 roof-mounted collector fields. The solar thermal system is designed to supply around 24% of the final thermal energy demand (incl. network heat losses) of the new buildings with a heated floor area of approx. 40,000 m<sup>2</sup>.



**Figure 15: View on collector array of the largest plant in the urban quarter "Gutleutmatten" as well as the piping-system of the heat network.** (Source: Fraunhofer ISE, badenovaWÄRMEPLUS GmbH & Co. KG)

**Project fact box:****General information:**

Location: **Gutleutmatten in Freiburg i. Br., Germany**

Urban scale of area: **81,500 m<sup>2</sup>**

Population in the area: **1,500**

Building mix in the area: **Multi-storey (three to nine) residential buildings**

**39.000 m<sup>2</sup> residential (98%)**

**1,000 m<sup>2</sup> cultural and social facilities (2.0%)**

Heat consumer characteristics in the area: **100 % medium size consumers (80-800 MWh/a)**

Plant owner: **public owned private utility**

**Specific information:**

Total gross floor area: **57,000 m<sup>2</sup>**

Heated floor area: **approx. 40.000 m<sup>2</sup>**

Final thermal energy demand (incl. network heat losses): **approx. 2,900 MWh (design value)**

Useful building thermal energy demand: **2.600 MWh (design value)**

Network heat losses: **approx. 300 MWh/a (10%) (design value)**

Heating grid trench length: **1,540 m**

No. of building substations: **38**

Supply/Return temperature levels: **75/40 °C (heating network design temperatures)**

(Thermal) energy supply technologies: **N-Gas CHP (600 kW<sub>el</sub>/654 kW<sub>th</sub>), N-Gas Boilers (4,000 kW), Solar thermal (~ 1.400 kW<sub>p,th</sub>)**

**Specific information about the solar thermal part:**

Solar thermal collector area: **2,200 m<sup>2</sup><sub>gross</sub> / 1,990 m<sup>2</sup><sub>aperture</sub> (38 roof-mounted systems of between 7 and 145 m<sup>2</sup>)**

Thermal energy storage volume: **177 m<sup>3</sup> (split into 38 units of up to 15 m<sup>3</sup>)**

Annual solar energy yield: **780 MWh (design value)**

Solar fraction: **30% (based on useful building thermal energy demand)**

Specific annual solar energy yield: **390 kWh/ (m<sup>2</sup><sub>aperture</sub>·a) (design value)**

**Economics figures:**

Total building project: **≈ 120 MEUR (excl. VAT)**

Total cost of heating system: **≈ 3.25 MEUR (excl. VAT); grant/funding: 2.95 M EUR (20.2%)**

**Solar thermal collector field + piping + storage + control 53.8% (1.75 MEUR)**

**Building heat transfer stations 4.6% (0.15 MEUR)**

**Heating grid 16.4% (0.8 MEUR)**

**Ancillary construction costs, other costs 6.2% (0.2 MEUR)**

**Consulting / engineering / R&D 10.8% (0.35 MEUR)**



#### 4.4.1 Introduction and description

The new development area “Gutleutmatten”, with 500 households, 40,000 m<sup>2</sup> living area and a heat demand of approximately 2,600 MWh/a, will be constructed in Freiburg between 2013 to 2018, within the framework of the inner-city development. Within the scope of this project, a decentralized solar thermal system will be integrated to a heat supply system based on a Combined Heat and Power (CHP) district heating system. The operation of the CHP will be optimized so as to seek the best possible interaction with the electricity network and aiming to minimize the distribution losses of the local heating network. Key topic of the concept is to implement innovative operational management, and to deduce overall rules to the long-term perspective of solar thermal heating in similar urban districts. The main innovative objective of this heat supply system is to realize an innovative integration of solar thermal systems in the local heating network which reflects the availability and cost of space in dense urban environments. The approach is a decentralized coupling of the solar thermal system which aims to shut down the operation of the local heating network for a sum of at least 3 months during summertime.

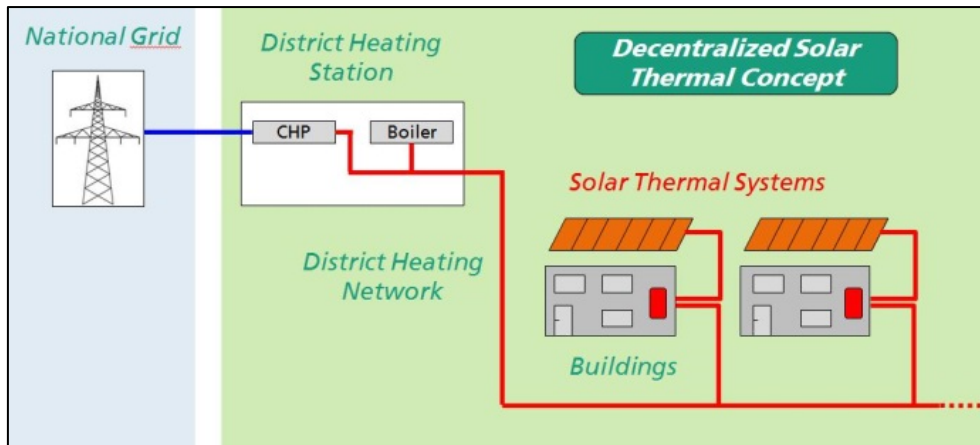

**Figure 16: Development area Gutleutmatten in Freiburg i. Br. incl. principle diagram of the hydraulic solar thermal integration to the local heating grid** (Source: City planning office Freiburg i. Br., Fraunhofer ISE, badenovaWÄRMEPLUS GmbH & Co. KG)

#### 4.4.2 Technical description of the concept and innovative approaches

Combined heat and power (CHP) district heating systems are a reasonable and well established solution to meet a residential area’s energy demand. While the produced heat is used to provide the buildings’ space heating and domestic hot water (DHW) requirements, often the generated electricity is fed into the grid at a fixed tariff. In future, the income from this supplied electricity is expected to depend on the national residual load – the load that remains after national photovoltaic (PV) and wind turbine power has been fed in – and hence be coupled with the electricity prices at the European Energy Exchange. One promising technical solution to adapt the operation of conventional CHP district heating systems is to enhance the scheme with decentralized solar thermal collectors. Due to the correlation of PV power and solar heat production, at periods when there is a low residual load due to PV power, solar heat can be used to meet the heat demand, whilst the CHP district heating system will temporarily be decommissioned. Thus this solution is improving both the thermal performance by reducing heating network losses due to the decommissioning and a better adaptation of CHP operation to the electricity market.

The heat supply concept for “Gutleutmatten” is going to be a composition of a CHP district heating system and decentralized solar thermal systems. There will be about 38 substations. The solar thermal collectors are going to be installed on the buildings’ roofs and will amount to approximately 2,200 m<sup>2</sup> in total. The decentralized thermal storages will result in about 177 m<sup>3</sup> in total. The district heating station consists of a CHP unit with 600 kW<sub>el</sub>/654 kW<sub>th</sub> and several gas boilers with 4 MW in total (see Figure 17). A sophisticated control scheme allows the decommissioning of the heating network in a way that the heating network will be put into operation only in those segments where a heating demand occurs. Thus excess heat from a specific collector field can be transferred from one building’s storage to a neighborhood building.



**Figure 17: Schematic view on the integration of the local solar thermal system and storage into the district heating network** (Source: Fraunhofer ISE)

The entire building stock meets German low energy building standard “KfW-Effizienzhaus 55” with a specific space heating demand of about 35 kWh/(m<sup>2</sup>.a). The domestic hot water demand is designed with 30 kWh/(m<sup>2</sup>.a). Total heat demand of the urban district sums up to 1,400 MWh/a for space heating and 1,200 MWh/a for domestic hot water (DHW) preparation and is supplied by natural gas fired district heating (70 %) and distributed solar thermal (30 %).

The delivery of the DHW in the buildings is partly organized by central fresh water stations as can be seen in Figure 18, partly as flatwise local fresh water stations.



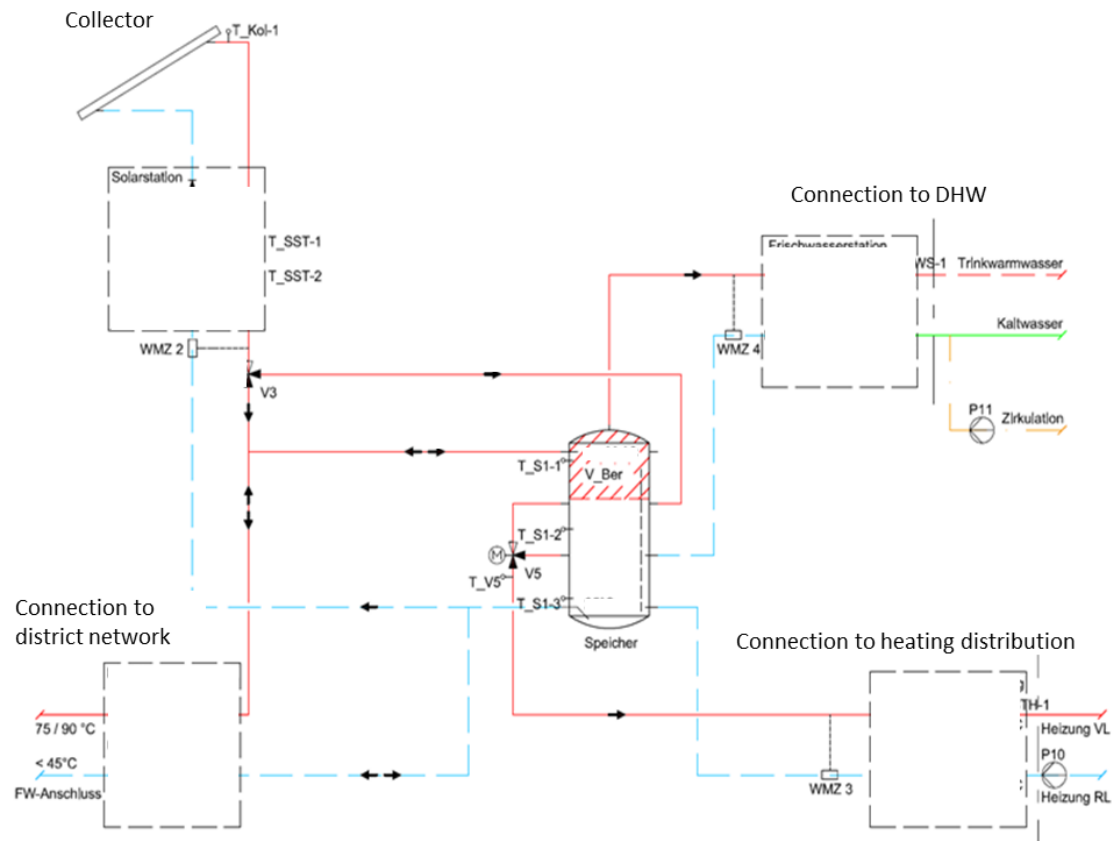

Figure 18: Layout of the hydraulic system in the buildings (Source: badenovaWÄRMEPLUS GmbH & Co. KG)

#### 4.4.3 Decision and design process

*Why was this project initiated, to answer which need?*

The project was initiated by the City of Freiburg, where there is a local requirement for an energy concept for all new developments based on public owned ground. In addition municipal building codes require that buildings energy demand for heat does not exceed 55 kWh/(m<sup>2</sup>·a) for domestic hot water and heating. The energy concept for Gutleutmaten evaluated different solutions with and without a heating grid and different heat sources like biomass, gas and solar thermal.

badenovaWÄRMEPLUS GmbH&Co. KG and Fraunhofer ISE offered as additional option the described innovative solution combining Bio-Gas based CHP in combination with local Solar thermal production and smart heating grid operation. Due to the low CO<sub>2</sub>-emissions of this solution and the innovative aspects this solution was selected.

*Which stakeholders were involved in the project?*

- City of Freiburg with several city council departments (a.o. energy department and town planning)
- Regional Utility Company (badenovaWÄRMEPLUS GmbH&Co. KG)
- Fraunhofer Institute for Solar Energy Systems ISE

*Which resources were available before the project?*

- Strong participation and intervention by local administrative facilities and overall good co-operation between involved actors
- Dedicated individuals with high specific expertise

*Who (what) were drivers and who (what) were opponents (barriers) – and why?*

On the one hand several important stakeholders joined forces in order to come up with a climate friendly and innovative solution. On the other hand subsidies have been enablers for innovative

approaches and investments for specific technologies like solar collectors or enhance quality of the district heating network (*Innovationsfond* of badenovaWÄRMEPLUS GmbH&Co. KG and German state owned bank *KfW*), specific research and monitoring (German Ministry for Economy and Energy *BMWi*).

Barriers to overcome have been high initial investment costs (compared to standard solutions) resulting in relative high levelized cost of heat as well as time-consuming communication with very diverse group of building owners.

*What have been the main challenges regarding decision finding?*

The main challenging point was to define an acceptable level for the customer's financial contribution and energy price vs. the environmental approach. Background is the already high cost for new building at the location. In addition the development of a reliable cost calculation for the whole system in a very early design stage was challenging.

*What was finally the crucial parameter for go /no-go decision?*

The innovative part of the solution in combination with the availability of funding was the base for the decision.

#### **Financing issues:**

*What have been the main challenges / constraints regarding financing?*

- Implementation of technical innovations and specific cost for design

*Which business model applies to the project?*

All building owners are obliged to contract with the utility operating the district network and the collector system including storage and transfer stations. Heat customers are supplied with heat including service and operation of the whole distribution for a basic rate per m<sup>2</sup> useful area plus an energy rate per kWh.

#### **Technical issues:**

*What have been major technical challenges / constraints regarding system design?*

- Limited areas on the roofs due to restrictions by the city's planning office
- Interface roof (erection of the solar thermal collector fields by the energy supplier on the roofs of the buildings owned by the real estate developers)
- Communication effort with more than 20 different architects and planners of the buildings
- Hydraulic set-up, control and operation of the Solar collector fields in Interaction with the district heating network

#### **Description about the design approach applied:**

*Which design targets have been set and why?*

Superior target was to design and implement a highly energy efficiency and low-carbon energy heat supply for the new urban quarter Gutleutmatten. More specifically, it was decided to implement a solar-assisted micro-heating grid in close distance to the existing district heating supply area which should meet optimum cost-performance targets. In addition the enhancement of the energy performance by reduced distribution losses and the compatibility to the future development of electric energy system.

*Which decision steps lead to the retained solution?*

1. Energy concept was developed by a technical consultant ordered by the municipal government
2. Idea for a solar-assisted low-temperature micro-heating grid backed up by district heating was brought in by badenovaWÄRMEPLUS GmbH&Co. KG and Fraunhofer ISE and further elaborated in interaction with the energy department of the city.

3. City government approved the technical concept.
4. Applications for subsidies on investment for innovative technologies, project-specific R&D as well as monitoring were handed in (national R&D promotion scheme, badenovaWÄRMEPLUS GmbH&Co. KG innovation fond)
5. Technical project development by utility supported by scientific accompaniment and monitoring by scientific partner (Fraunhofer ISE, Germany)

*Which tools have been used during the design phase?*

- Spread sheet calculations and simulation tools of the utility and the scientific partners
- control group meetings

*What have been the main challenges in the design phase?*

- To identify and bring together all necessary stakeholders and actors
- Communication and decision-making processes
- Setting up of an appropriate tender model
- Development of hydraulic schemes and control algorithms

*What have been the most crucial interfaces?*

- building owners ↔ politics
- utility ↔ building owners

#### 4.4.4 Lessons learned (barriers and success factors)

*What have been major success factors?*

- The common will
- The availability of different expertise within the core group
- R&D project with resources for innovation
- Climate policy of the City
- Clear targets at the beginning and a clear communication into the public space

*What have been major bottlenecks?*

- Acceptance of an energy concept based on a community system like district heating in times of rising individualism in the society

*What are the major lessons learned?*

- Political will and support are very conducive
- The cost of solar thermal supply concepts are dominated by installations costs and connected cost for risk management. In addition cost of design and planning is very sensitive to distributed ownership of buildings.

#### 4.4.5 Summary

The case of **Gutleutmatten** is good example of a **low-carbon energy supply system** with a very effective and productive cooperation between utilities and applied research. Based on a superior target (high efficiency, high share of RES, district heat as auxiliary service) the design of the heat supply system has a potential to act as a blueprint for integration of solar thermal and district heating as well as for optimized operation of heating networks.

**From a technical point of view**, local production of solar thermal has the potential to lower the distribution losses using smart communication technology to optimize the heat supply of specific buildings. The newly developed system enables the connected CHP to operate in line with the electricity market. The hydraulic integration of medium sized collector areas is still a complex task regarding design and put into operation.

**From an organizational point of view** the good cooperation between city government, utility and research institute was a key success factor. The challenge is to reach consensus regarding acceptable levelized cost of heat for a low-carbon supply system. Moreover, applying for subsidies and participation in R&D projects (national and utility funded) helped to deeply analyze and proof innovative (out-of-the-box) ideas, to co-finance new technologies and to disseminate achievements to a broader audience.

## 4.5 Solar-assisted residential area “Vallda Heberg” in Kungsbacka, SE

### Authors:

Martin ANDERSEN	Dalarna University, SE Chalmers University of Technology, SE	<a href="mailto:maar@du.se">maar@du.se</a>
Jan-Olof DALENBÄCK	Chalmers University of Technology, SE	<a href="mailto:jan-olof.dalenback@chalmers.se">jan-olof.dalenback@chalmers.se</a>



**Figure 19: Aerial view on the “Vallda Heberg” residential area, Kungsbacka, Sweden** (Source: Eksta Bostads AB). In sum, 570 m<sup>2</sup> flat plate collectors (FPC) and 108 m<sup>2</sup> evacuated tube collectors (ETC) roughly supply 29% of the final thermal energy demand (incl. network heat losses) of the buildings with a heated floor area of around 14.000 m<sup>2</sup>.



**Project fact box:****General information:**

Location: *Suburban area outside the city of Kungälv (South of Gothenburg)*

Urban scale of area: *5.3 ha*

Population in the area: *260 (128 living units)*

Building mix in the area\*: *SFH 38.4%, MFH 9.3%, AB 52.3%*

*26 modulated passive houses developed by NCC*

*4 multi-family buildings (16 living units)*

*6 row-houses (22 living units for seniors)*

*64 apartments as home for elderly people*

Consumer mix in the area\*\*: *Small 48%, Medium 52%*

Plant owner: *EKSTA Bostads AB (Public entity)*

**Specific information:**

Heated floor area: *14 000 m<sup>2</sup>*

Final thermal energy consumption (incl. network heat losses): *~850 MWh/a (measured 2015)*

Useful thermal energy consumption: *640 MWh/a (measured 2015)*

Network heat losses: *~210 MWh/a (measured 2014/2015) (25%)*

Heating grid trench length: *>1 000 m*

No. of consumer substations: *four main substations / >50 consumer substations*

Supply/Return temperature levels: *70/50 °C (primary network), 60/50 °C (secondary network)*

Heat supply technologies: *Wood-pellet boiler (300 kW), Oil boiler (500 kW, backup), Solar thermal (~ 475 kW<sub>p,th</sub>)*

**Specific information about the solar thermal part:**

Solar thermal collector area: *678 m<sup>2</sup><sub>aperture</sub>*

*Flat plate collectors (FPC): 570 m<sup>2</sup><sub>aperture</sub>*

*Evacuated tube collectors (ETC): 108 m<sup>2</sup><sub>aperture</sub>*

Thermal energy storage volume: *~75 m<sup>3</sup> (split into 13 units)*

Annual solar energy yield: *250 MWh (design value) / 230 MWh (Measurements)<sup>1</sup>*

Solar fraction: *29 % / 37%<sup>1</sup> / 40% (Net/Gross/ Gross design)<sup>2</sup>*

Specific annual solar energy yield: *369 kWh/ (m<sup>2</sup><sub>aperture</sub>·a) (design value)*

**Economic figures:**

Total building project: *~ 340 M SEK (38 M EUR) (incl. VAT and construction cost)*

Solar heating system: *~ 3.3 M SEK (0.4 M EUR) (incl. VAT and construction cost)*

*Subsidies: 25% of solar thermal system cost (LÅGAN programme + Swedish construction industry's organization for research and development (SBUF))*

\* SFH: single-family home; MFH: multi-family home, AB: apartment block

\*\* Small consumers (SFH + MFH): <80 MWh/a, Medium consumers (AB, schools, etc.): 80-800 MWh/a

[1] Values originate from an analysis made by the national program LÅGAN, funded by the Swedish Energy authority. The analysis stated measured energy and estimates based on six months of measurements for parts of the system.

[2] Net solar fraction means output solar collector energy divided by sum of total energy into the system and thus incorporates system losses. Gross solar fraction means output solar collector energy divided by end user heat demand and thus does not include the system losses.

#### 4.5.1 Introduction and description

The construction of the Vallda Heberg residential area commenced in 2011 with last building finished in 2016. It is a suburban area outside the city of Kungälv (south of Gothenburg) on the Swedish west coast, result of the collaboration between housing developer NCC (acting as contractor) and municipal housing company EKSTA Bostads AB (owner).

EKSTA has been delivering green housing solutions since the 1980's, always with a little lower heating demand than required in the Swedish building code. The energy system solution offered has for the most part consisted of small district heating systems with different combinations of wood-chips/pellet fired boilers and solar collectors acting as heat supply. Earlier projects had managed to achieve up to 35% solar fraction based on heating demand, which was set as a benchmark in the new project, subject to improvement.

The conceptual approach at project initiation was to build a number of single-family houses for sale, in addition to several multi-family buildings and an elderly home with apartments for rent. At the time, NCC developed a modular series-produced house whose heating demand was in agreement with the Swedish passive house standard (i.e. near zero energy buildings), which suited the project rather well. Hence, this house and the remaining building stock were all purpose built to supply a low-energy, 100% renewably heated living area. Main objectives for the project include:

- 100% renewable heating solution
- 40% solar fraction (based on useful building thermal energy demand)
- Passive house standard (near zero energy)
- Reduction of heat distribution cost

Although the challenges related to the fulfillment of the project were few, as all involved parties were experienced developers within their respective fields, some aspects proved challenging:

- Achievement of a higher (40%) solar fraction without use of seasonal storage
- Acceptable level of heat distribution losses when supplying a load of low heat demand
- Alternative to steel-pipe heat distribution, with similar performance at lower cost

The main approach to meet these challenges was to implement novel heat distribution, using a central wood-pellet boiler to supply a primary distribution network, delivering heat to four substations containing a decentralized storage. The substations couple to a secondary distribution network utilizing PEX pipes, with hot water circulation to serve the heating demand. Roof integrated flat plate collectors on the larger buildings and substations form solar roofs that deliver solar heat, used for pre-heating of domestic hot water in the substations, before delivery to the load. In addition, evacuated tube collectors are installed at the central boiler house with steeper inclination angles for optimized solar energy yields in winter (as well as reduced overheating in summer).

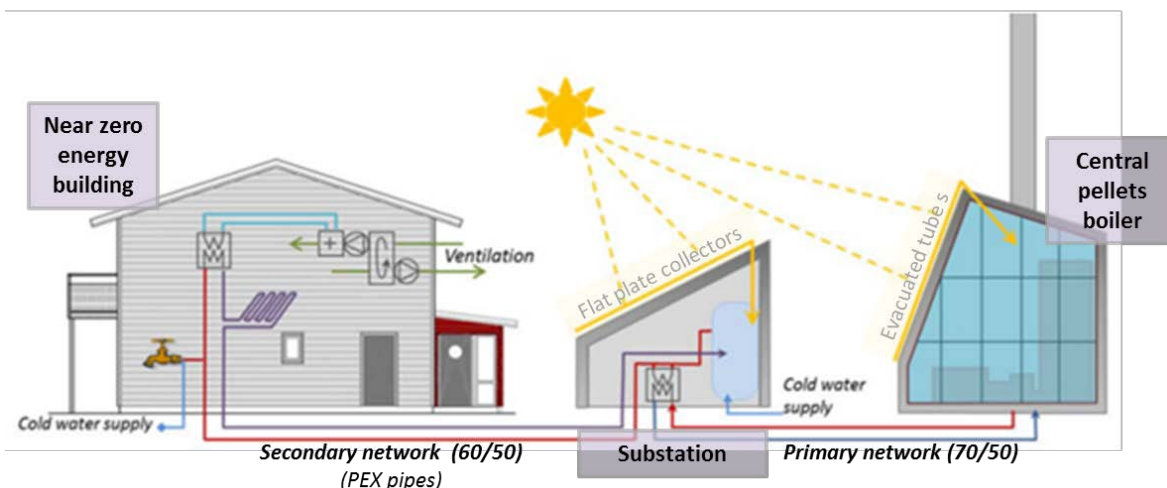

**Figure 20: Schematic of the technical system in Vallda Heberg** (Source: Adapted from Markgren Arkitektur AB and Mats Abrahamsons Arkitektkontor AB)

#### 4.5.2 Technical description of the concept and innovative approaches

The holistic approach used in construction of the area is extraordinary in the way that by using EKSTA Bostads AB as purchaser and later owner and operator, it was possible to tie politics to business policy. The political will to move towards a renewable society could be expressed clearly by designing the area to be supplied 100% by renewable energy, whereof 60% biomass and 40% solar heat. By using NCC, manufacturer of housing to meet the Swedish passive house standard, as contractor and project manager, it could be shown that economic potential and political sustainability goals can be realized at the same time. **The sales model employed to sell the housing units naturally took the costs of the heating system into account and thus guaranteed that the area would be supplied by a large fraction solar energy at the expense of about 1% of the total project cost.** From this aspect, purchasers of a house/apartment received renewable energy as a main source of energy as part of a package deal, avoiding they be deterred by potential costs seemingly too high for the individual.

The innovative hydraulic scheme employed in Vallda Heberg includes conventional steel double pipes in the district heating primary culvert, delivering heat to four substations. In addition, flat plate solar collectors installed on the multi-family houses and the substations deliver heat to storage tanks placed in the substations. The combination of heat from these storage tanks and the primary culvert is then used to supply the secondary culvert.

Heat is distributed through a so-called GRUDIS system where warm water is circulated between the substation and the load in a secondary culvert, which consists of extruded polyethylene (PEX) piping in an evacuated polystyrene (EPS) casing. The circulating water supplies space heating (SH) through a glycol loop, by heating up incoming fresh air after it passes the outlet air heat-recovery unit, before running through a floor loop in the dwellings. This provides both an active, user controlled heating solution in addition to providing passive, year round floor heating. Domestic hot water (DHW) is supplied and pre-heated in the substation, then distributed with the warm water circulation to the load where it is drawn off.

This way, a relatively large solar fraction is ensured, due to the constant heat load of the circulation loop and the relative size of DHW demand to space heating demand. The pre-heating solution makes it possible to ensure that solar heat is the preferred source of heat, when available.

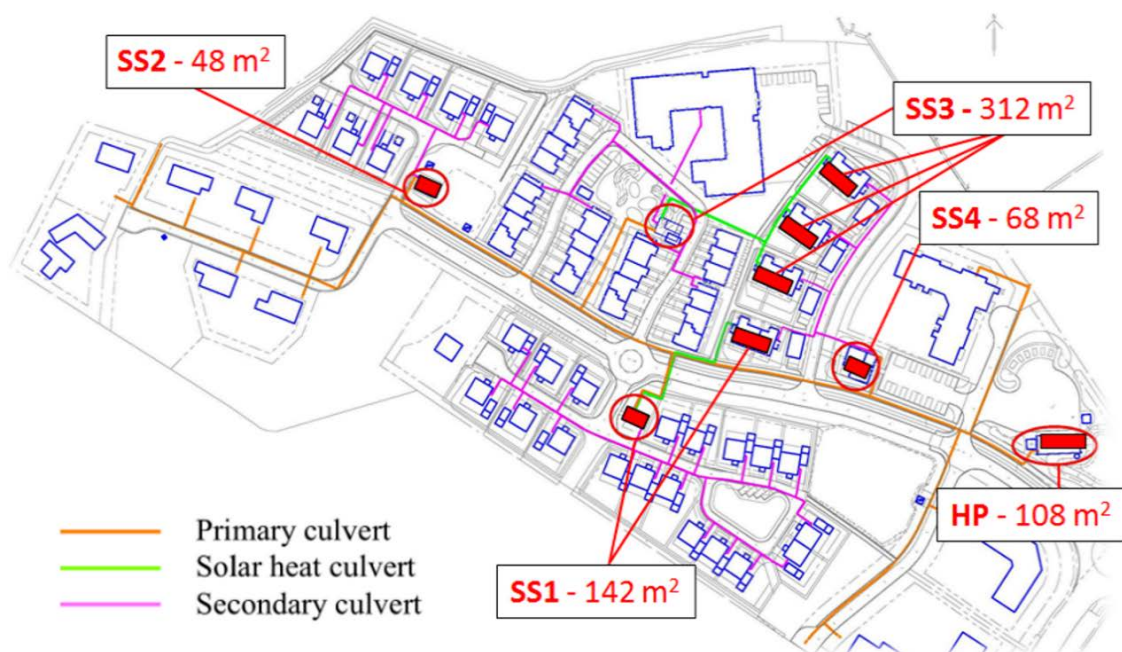

**Figure 21: Schematic showing the heat distribution network in Vallda Heberg** (Source: Master thesis of Olsson and Rosander, 2014). Primary culvert refers to conventional double steel piping, solar heat culvert refers to in ground insulated copper pipes and secondary culvert refers to PEX circulation piping. Rectangles filled in red indicate solar thermal collector fields; SS stands for substation (SS1 – SS4); HP stands for central heating plant.

### 4.5.3 Decision and design process

*The following questions and answers aim at understanding the context (political, urban, energy) and the pre-design steps that led to the retained solution.*

#### **General / organizational issues:**

*Why was this project initiated, to answer which need?*

The project was initiated by the municipal housing company EKSTA Bostads AB to cover the increasing need for dwelling in the already pressured housing market of the greater Gothenburg city area. While fulfilling the need of housing, it was simultaneously of great importance to progress in an exemplary manner with regards to energy supply and efficiency, in order to address present-day issues of climate change and sustainability by providing a model for how to combine economy and sustainability.

*Which stakeholders were involved in the project?*

- Contractor (including project management): NCC Construction Sweden AB
- Real estate owner: EKSTA Bostads AB - Municipal housing company
- Consultants: Markgren Arkitektur AB, Mats Abrahamsson Arkitekter AB, NCC Environment, Andersson & Hultmark and BA-Elteknik.
- Collaboration: end users, Kungsbacka municipality

*Which resources were available before the project?*

Electric heating has traditionally been used extensively and was one alternate option considering passive housing with low energy needs. However this would increase the pressure on the electric grid and also would require measures to ensure that the energy consumed was renewable.

District heating could be supplied from nearby Kungsbacka, but would entail a larger network extension, speaking in favor of the isolated smaller district heating system chosen.

As gas is not used extensively in Sweden, in terms of primary energy, biomass and solar were two readily available and easy to use energy sources.

*Who (what) were drivers and who (what) were opponents (barriers) – and why?*

The main driver was the real estate owner, Eksta Bostads AB, which in turn is owned by Kungsbacka municipality. The project was an answer to the housing situation experienced in most major cities, where the market is under mounting pressure. Eksta in turn maintains the intent to gather information on practicality of different technological solutions, which inclines their projects towards innovation while supplying renewable technical solutions. In short, they decide what they want, then work out an appropriate solution.

NCC as contractor had a financial interest as a housing manufacturer. The opportunity to test a new modular (passive) house along with the business opportunity represented by selling these houses simultaneously was, if not a driver, certainly a beneficial support.

Not many barriers were found. The area is regulated in the spatial plan as a development area for housing, so that the potential barriers would have related mainly to the choice of energy supply. At present, waste is currently being imported to Sweden's major cities for incineration in larger district heating plants, complementing recycled industrial heat from the outskirts of the city. Gothenburg has a large share of industrial recycled heat, while Kungsbacka has none.

As such, the most promising option was biomass in line with the vast resources available in Sweden.

*What have been the main challenges regarding decision finding?*

Key challenges were related to those inherent to the technical outlay of a low energy demand system. The optimal solution for low energy housing (passive according to Swedish standard) of the class considered, with airtight envelopes, is difficult to find and requires a lot of attention to load

balance and detail planning. The challenges lie in making a complex solution involving a lot of control systems work in a simple manner. Eksta chose to go for a solution proven in their earlier projects, while implementing a few new elements (passive house, GRUDIS culvert and evacuated tube collectors) and thus found their challenges in compromising between the operation of these.

It was generally perceived a benefit that Eksta acted as both realtor and energy supplier to the housing area, as this meant that all larger decisions could be taken beforehand in the planning stage, which meant a more complete set of boundary conditions for all involved parties. The added security posed by this organization of the process voided any potential larger challenges often seen when a larger set of actors are involved in a project without a designated order of project phases.

*What was finally the crucial parameter for go /no-go decision?*

There were no crucial parameters related to the evaluation of the project viability. The decision had been made on a political level in Kungsbacka municipality to build new housing in Vallda Heberg. The cost of the energy system was considered irrelevant to the decision regarding choice of energy supply as a whole, as it made out about 1% of the overall cost, which is considered well within any margin on the estimated cost.

#### **Financing issues:**

*What have been the main challenges / constraints regarding financing? Which business model applies to the project?*

NCC was contracted to build the whole residential area for customer Eksta. The single-family houses were sold off by NCC as one of their products, whereas the remaining facilities were taken over and rented out by Eksta. The energy system was purchased and is operated by Eksta, which sells energy to the inhabitants of the area. This is the municipal housing model.

In planning this project, contractor NCC had considerations about the price level of the houses offered, as this was about 13% higher with the additional climate shell, as opposed to the same houses in a higher energy class. Therefore, there was some doubt related to the market reaction when the dwellings were put out on sale. However, the rate at which the sale proceeded exceeded every expectation and thus the willingness in the market to pay for renewable energy solutions and energy efficient measures seems high.

There were no additional challenges related to financing as the end product was considered most relevant and cost issues were largely secondary. It should be mentioned that the project enjoyed part of this economic freedom due to dedicated subsidies.

#### **Technical issues:**

*What have been major technical challenges / constraints regarding system design?*

The complex interaction between control systems and solar collectors has proven to be a significant challenge in systems with a higher degree of complexity, like the one in Vallda Heberg. Some challenges were experienced during commission of the solar system, as it received air pockets in the piping. This is largely seen as an issue related to installer experience and could be easily resolved.

One constraint on the system design put on the solar system was that the increase in solar fraction should not be made on the expense of an increased storage volume. Increasing the solar fraction upwards of 35%, it is natural to consider larger storage units for seasonal or part-seasonal storage. However, this was never an option in a system of this scale.

The choice of heating system for the dwellings incorporated a floor heating loop, which posed a challenge during dimensioning. Seeing that the climate shell was of such a standard that little auxiliary heat was needed to maintain adequate living comfort for the inhabitants, it was necessary to insulate the floor-heating loop to avoid excessive indoor temperatures. This limited the power to an acceptable level for year round unregulated operation.



For the elderly home, the idea of passive- and air heating was abandoned after thorough consideration had been made to the user knowledge of, and familiarity with, newer systems. Older users are often accustomed to user controlled heating, i.e. radiators, which made this a preferred choice in the elderly home. This meant having to separate the SH and DHW supply in the building, which added somewhat to the system complexity, but had no particular consequences for the system otherwise. In fact, it had the added benefit of reducing the return temperature in the primary culvert.

On the other side, during a user survey on the senior living quarters (22 row houses), it was found that the senior citizens had a tendency to use a lot more energy than first calculated in the design phase and that they would extend the heated area by incorporating the hall into the house, which further increased their energy consumption.

***Description about the design approach applied:***

*Which design targets have been set and why?*

Previous projects by EKSTA have achieved solar fractions up to 35% (of end user heat demand) and this was set as benchmark for the Vallda Heberg project. The new target was 40% solar fraction and the remaining supplied by biomass in order to improve the amount of heat covered by solar from earlier projects. Measurements have shown solar coverage close to the target, upwards of 37%, which is slightly less than expected. However, this has largely been due to operational problems like pump failure, air entrainment in the pipes and even control system faults. Work is ongoing to improve the operational strategy by implementing different solar loop pump control and faster fault detection, among others.

*What were the decision steps to lead to the retained solution?*

The layout of the energy system was chosen according to the constraints and challenges mentioned earlier. Once the solution of wood-pellets and solar energy had been chosen, it became a priority to find the most suitable way to increase the solar fraction without making significant increase in storage volume necessary. One of the major challenges with solar heat is that the peak production is in the summer, when the heat demand is at its lowest. Although the amount of DHW does not vary so much over the year, the overall heat demand is significantly lower in summer, which leads to two effects in particular:

1. A full diurnal storage and excess solar heat on hot days
2. Increased distribution heat losses due to large circulation compared to demand

Furthermore, it was desirable to lower the costs of the heat distribution system.

One way to deal with the challenges of excess solar heat was to install solar collectors on the heating central with a high tilt (70°), so that the increase in solar fraction would happen by collection of energy during the autumn-winter months where the demand is highest.

To address the second challenge, one proposed alternative was to lower the network temperature and preparing DHW in the substations. By preparing the DHW more centrally and at lower temperature, an extra heat exchanger for DHW preparation in the dwellings became obsolete, which in turn made the heating system cheaper and more efficient.

The lower temperature of the network secondary culvert lowered distribution losses during the summer and meant that a larger part of the circulation losses could be covered by solar heat, and the culvert itself would be cheaper, being made of EPSPEX.

Another alternative to the high distribution losses would have been to abandon the use of a district heating system. However, the options for individual heating generally had a higher price level and, in the instance of direct/indirect electrical heating would require installation of large arrays of solar PV panels. This was decided to induce an undesired level of complexity, as it would require use of private roof surfaces (i.e. SFH) which has juridical issues related to owner responsibility in the energy

regulations. Furthermore, with the lower efficiency of solar PV panels compared to solar thermal collectors, it was considered unfeasible to achieve a 100% renewable energy share.

*Which tools have been used during the design phase?*

For building simulations, IDA (ICE) was used. For cold bridges HEAT2. For culvert losses and ground effects a FEM analysis was done. Cost estimation is largely done with Wikells, a Swedish program for building and HVAC enterprise. Solar energy yield was mainly planned from operational data in other systems in the same region and experience.

#### **4.5.4 Lessons learned (barriers and success factors)**

*What have been major success factors?*

A survey of inhabitant comfort in the area largely shows that the population is very pleased with their housing. The energy efficient housing is popular due to low energy bills and the renewable energy solutions have seemed to work as planned. The market reports show that the area is a desirable place to live and the houses have seen a fair increase in value on the free market. The renewable energy solutions seem to aid to this.

NCC has had large success with their new house and has received prizes for it. The Kungsbacka municipality has also received a lot of attention and the Vallda Heberg residential area is featured as a gold example of best practice example in “Build up” - the EU portal for energy efficiency in buildings. Several research projects have been conducted and connected to the project and the residents have become accustomed to wide spread media attention and regular study tours bringing in “tourists” curious of the scheme.

*What have been major bottlenecks?*

None, so far. However, there have been some challenges related to the full operation of the system. In 2013 as the area was still only partly built, there were some startup problems. Control optimization required a lot of time as well as problems with leakages. Air entrainment in the solar loop pipes occurred in the beginning, leading to lowered production. In the first quarter and half of 2016, leakage of glycol from the circuit of the solar loop led to low production and the system log was rendered inactive, leading to missing log data. Log data has also been missing in the log system for larger periods of time, without any apparent reason.

An area prepared for larger villas has remained unconnected to the network for a longer time, which has led to some parasitic distribution heat losses. The commercial customers foreseen in the area were connected in 2016 and so the system is only fully connected at present. Preliminary results show that the system is performing better than in 2015, despite the operational challenges.

*What are the major lessons learned?*

Partly new system layout needs time to have all control issues in place. Some logging issues can be avoided by installing double sets of sensors. Regular monitoring should aim to reveal leakage problems early, IR thermography from air may prove useful.

Investigation of reasons for higher-than-theoretical values of energy consumption show that user behavior differ significantly in some cases from that assumed in initial energy calculations. Particularly elderly have an increased consumption to reach comfort levels which may be planned for in the design phase by scaling the solar system and storage accordingly.

*What should be transferred from this project?*

The project is continuously evaluated and it is anticipated that the majority of solutions will be transferred to future projects, if applicable. In particular the EPSPEX system for heat distribution has proven to be economically and technically preferable, with lower overall cost and higher practicality due to a shorter installation time than conventional steel pipes. Furthermore, it has been seen that the investment cost for a renewable energy system has a negligible influence on the attractiveness of a residential area and the housing offered. The implementation of such a system becomes much

more feasible when the energy system cost is seen in relation to the overall system cost – in which it becomes apparent that the additional cost for a renewable energy solution is such a small fraction, that it is considered irrelevant for all involved parties.

#### **4.5.5 Summary**

The Vallda Heberg residential area is an exemplary project under many aspects. Coupling highly insulated house, 100% renewable energy production, including 40% of solar energy without seasonal storage, and heat district distribution, the project was able to reach the initial ambitious objectives.

This achievement was made possible by elaborating a novel and complex heat distribution system. The heat district energy system is composed of different kinds of renewable energy sources (solar radiation and wood pellets), different types of heat pipes, different types of solar absorber technology and decentralized energy storage. This great achievement is even reinforced on the economic point of view. Indeed, the willingness of the market to access to sustainable housing solution was exceeding every expectation

The result of these measures collectively count as a great achievement for all involved stakeholders and has received widespread media attention.

## 4.6 Solar assisted apartment blocks “La Cigale” in Geneva, CH

### Authors:

Gabriel RUIZ	CREM	<a href="mailto:gabriel.ruiz@crem.ch">gabriel.ruiz@crem.ch</a>
Bernard THISSEN	Energie Solaire SA	<a href="mailto:b.thissen@energie-solaire.com">b.thissen@energie-solaire.com</a>

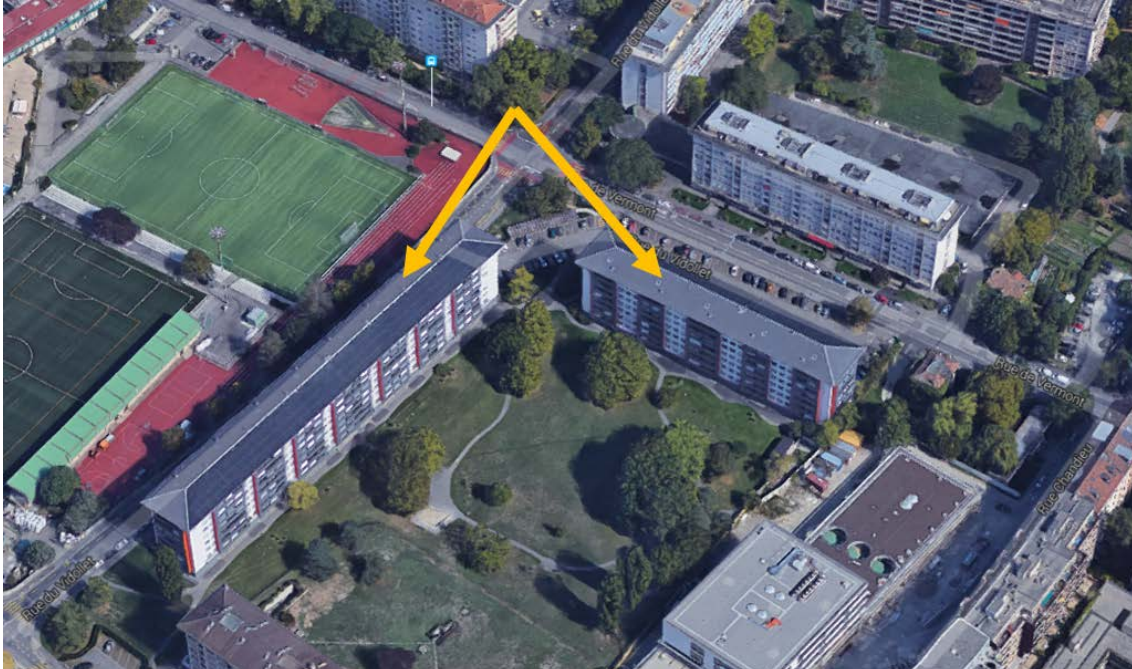

Figure 22: Aerial view on the solar assisted apartment blocks “La Cigale” in Geneva,, Switzerland. (Source: Google Earth)

**Project fact box:****General information:**

Location: Apartment blocks in Geneva, Switzerland

Urban scale of area: N/A

Residents in apartment block: 458 residents in two buildings for a total of 273 apartments

Consumer characteristics: 100% residential consumers

Owner: Private housing cooperative

**Specific information\*:**

Heated floor area: 18,999 m<sup>2</sup> (7,343 m<sup>2</sup> for Vermont and 11,656 m<sup>2</sup> for Vidollet)

Thermal energy demand (inkl. Network heat losses): 1,416 MWh/a

Useful thermal energy demand: 1,260 MWh/a

Heat losses (storages and network); 11 % (156 MWh/a) of thermal energy demand

Building heat distribution: 4-pipe network with centralized DHW tank

No. of building substations: 1 in each building

Supply/Return temperature levels: 40/35 °C for heating / 55/35 °C for DHW (design values)

Thermal energy supply system:

Compression heat pump 2 x 65 kW + 3 x 65 kW (@B-9/W45)

1,740 m<sup>2</sup><sub>gross</sub> unglazed solar water collectors (~ 1.2 MW<sub>p,th</sub>)

2 x 30 m<sup>3</sup> latent heat storage tank (water/ice)

1 x 12 m<sup>3</sup> and 1 x 20 m<sup>3</sup> stratified water tanks

1 x 1,5 m<sup>3</sup> and 1 x 2 m<sup>3</sup> DHW tanks

1 x 130 kW and 1 x 200 kW gas boiler

**Specific information about the solar thermal part\*\*:**

Annual solar energy yield and solar fraction:

948.1 MWh/a of solar generated heat (49.9 kWh/(m<sup>2</sup>.a) x heated surface)

Share of solar thermal: 56% indirect, 13% direct

Solar (thermal) fraction: 69% (referring to total heat demand incl. losses)

Specific annual solar energy yield: 561.3 kWh/ (m<sup>2</sup><sub>gross</sub>.a)

**Economic figures\*\*\***

Total building project (refurbishment + heating system): ~ 16.3 M EUR (20 M CHF excl. 8% VAT)

Total heating system (incl. dismantling of old system): ~ 1.5 M EUR (1.83 M CHF excl. 8% VAT)

Solar collectors (incl. mounting): ~457 k EUR (560 k CHF excl. 8% VAT)

Subsidies for solar system: ~110 k EUR

\* Nota Bene: Figures refer to the entire heated surface (2 buildings) and are extrapolated from values measured in 2016 at the "Vermont" building.

\*\* Nota Bene: Figures refer to the whole system and are extrapolated from values measured in 2016 at the "Vermont" building (out of the 2 buildings).

\*\*\* Nota Bene: Exchange rate CHF to EUR considered. Base date: 01.01.2014 (www.oanda.com, accessed on 01/2017)



#### 4.6.1 Introduction and description

'La Cigale' is a housing cooperative established in 1952 in Geneva, Switzerland comprising 273 apartments with a heated floor area of approx. 19,000 m<sup>2</sup>. Between 2013 and 2014, a full renovation of the building envelope with modernization of the heating system was realized.

The overall project achieved very ambitious goals: Building refurbishment decreases thermal energy demand by 55% (building complex meets low energy standards today) and moreover, 69% of the buildings whole thermal energy production is covered by 1,740 m<sup>2</sup> roof-integrated unglazed water collectors. This high solar fraction is achieved by means of a heat supply concept that combines compression heat pump, latent heat storage (water/ice) and solar thermal in a very smart way.

Depending on the season of the year, space heating and domestic hot water preparation is either provided by solar thermal only, or a combination of solar thermal with heat pump operation including charging / discharging of the ice storage is applied. A small natural gas boiler provides peak and backup capacity.

#### 4.6.2 Technical description of the concept and innovative approaches

For supply of space heating and domestic hot water (DHW) an innovative hydraulic concept called "IceSol" was applied for La Cigale (for further information see /1/). In each building, the concept combines compression heat pumps, unglazed solar thermal collectors as well as a latent heat storage (water/ice). Additionally, a small gas boiler for back-up and peak load operation is installed. Thermal energy is supplied via a four-pipe network with a centralized thermal energy storage and small centralized domestic hot water tanks in the basement (Figure 23). Temperature levels to meet space heating requirements are 40°C (supply) and 35°C (return). For DHW higher temperatures of 55°C are needed. A regular flashing of the dedicated DHW boilers at a temperature over 60°C allows to avoid legionella issues.

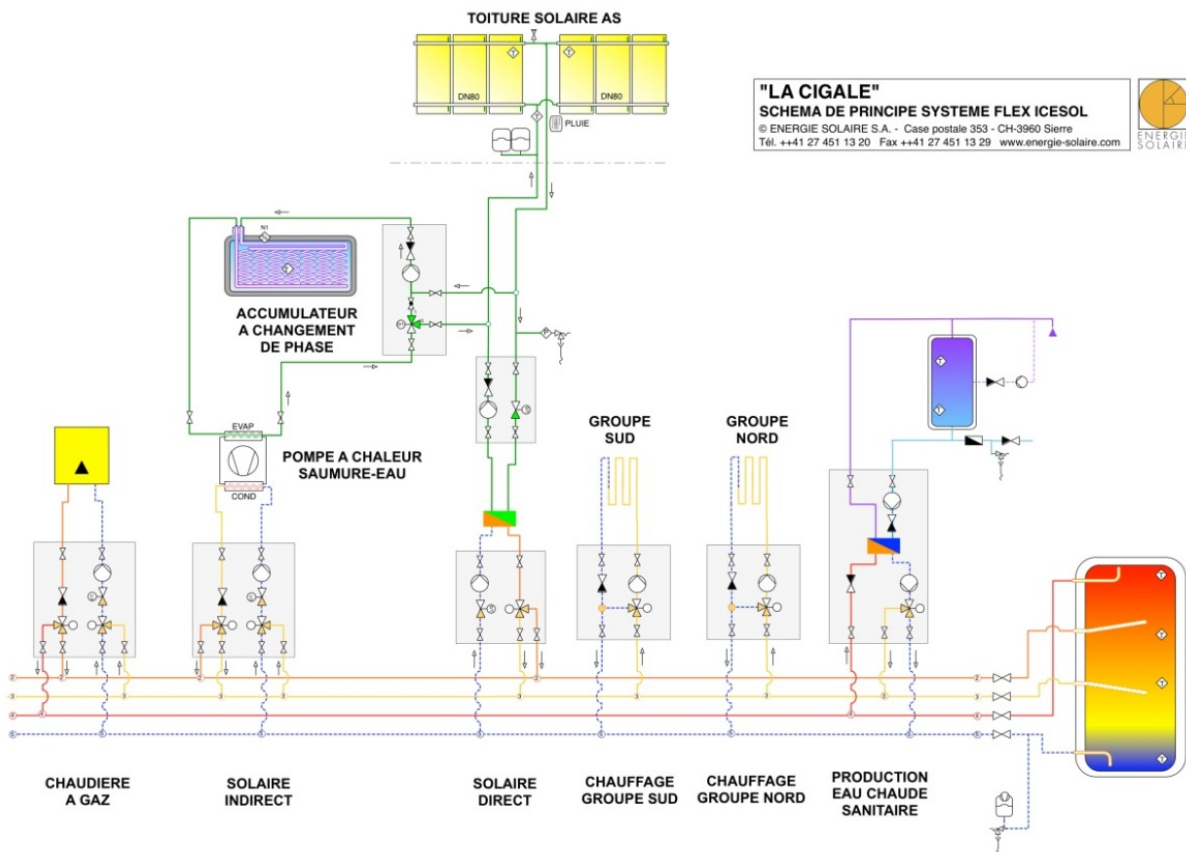

Figure 23: Hydraulic scheme of the heat supply system of "LA CIGALE". (Source: ENERGIE SOLAIRE S.A.)

### Operating principle of the IceSol system

The operating principle of the IceSol system may be split into four phases: During warm season, solar thermal collectors are directly feeding the centralized thermal energy storage with the required temperature - 40°C for heating and 55°C for DHW (Figure 24, left). In case solar thermal is not sufficient to cover DHW demand, solar thermal output is used to unfreeze and heat up (to max. 20°C) the latent heat storage (indirect solar operation) and the energy stored in the ice storage is utilized by the compression heat pump to meet the demand (Figure 24, right).

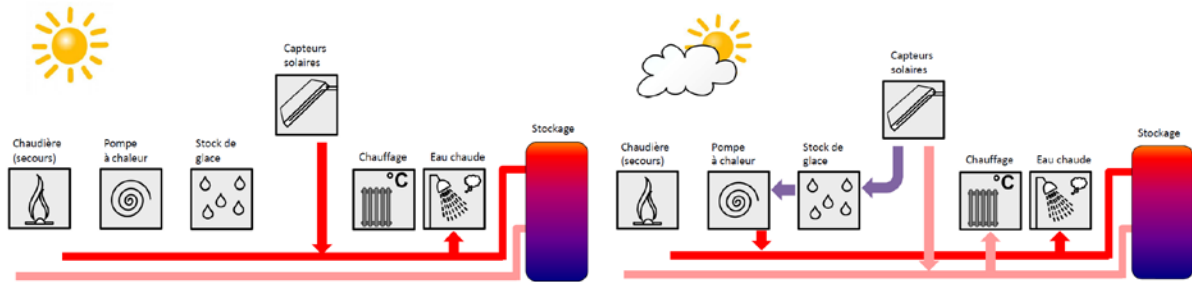

Figure 24: Principle diagram “LA CIGALE” – Warm season. (Source: ENERGIE SOLAIRE S.A.)

In case solar energy is too low for any direct service during cold season, all solar thermal heat is transferred to the ice/water storage (Figure 25, left). Its effect is, as worst case, to maintain the ice/water storage at 0°C, unfreezing the ice produced by the HP and thus keeping the system at a minimum of 0°C by playing with the latent heat. In case the latent heat storage is fully frozen, the storage can also be by-passed and heat pump can run in direct mode utilizing the solar loop as heat source. For peak heat demand at very cold winter days, a small natural gas boiler may be activated as well (Figure 25, right).

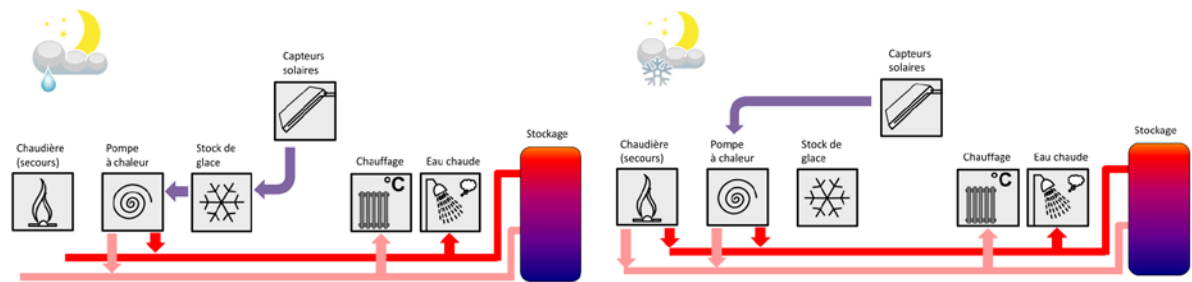

Figure 25: Principle diagram “LA CIGALE” – Cold season (source: ENERGIE SOLAIRE S.A)

The ice/water storage can work within the min 0°C to max 20°C temperature range. In the worst conditions (i.e. at 0°C) and when supplying DHW at 55°C, the heat pump performance coefficient is varying from a minimum of 3 to 4.7.

Gas consumption is designed to amount only 2% of the entire final energy demand for heating and domestic hot water (incl. losses) and was measured to be 6% in the second year of operation.

### 4.6.3 Decision and design process

The following questions and answers aim at understanding the context (political, urban, energy) and the pre-design steps that led to the retained solution.

#### General / organizational issues:

Why was this project initiated, to answer which need?

Major trigger of the whole project was the need for renovating the façade and for replacement of the old oil fired heating system. It was then decided to investigate both building renovation as well as modernization of the heating system whereas the following premises were stated beforehand:

- Decrease rental costs
- Reduction of CO<sub>2</sub> resp. reduction of fossil fuel demand for building energy services
- Use of eco-friendly construction materials
- Increased comfort, especially in winter
- Lower running costs for building maintenance
- Minimize nuisance while construction / renovation work

For the study different scenarios for were defined. In sum, two different qualities of building renovation were developed and analyzed (A) as well as six different heat supply scenarios (B):

- A1) Moderate renovation of the non-glazed surfaces only, energy target (heating, ventilation, DHW): ~210 MJ/m<sup>2</sup> (=58.3 kWh/m<sup>2</sup>/a) → 47% reduction compared to existing building stock
- A2) High quality renovation of the entire building envelope (incl. new glazing and loggia concept for the open balconies), energy target (heating, ventilation, DHW): ~110 MJ/m<sup>2</sup> (=30.6 kWh/m<sup>2</sup>/a) → 73% reduction compared to existing building stock
- B1) Heat pump coupled to geothermal probes
- B2) Gas boiler
- B3) Heat pump coupled to solar collectors
- B4) Solar thermal with seasonal storage
- B5) Wood boiler
- B6) Heat pump coupled to lake water

For decision finding a matrix was used considering costs (initial investment costs, annualized costs), energy efficiency as well as compatibility of the heating system with the respective building renovation alternative (Figure 26).

		Scénario 1	Scénario 2	Scénario 3	Scénario 4	Scénario 5	Scénario 6
		PAC Géo Th	Gaz Th	PAC Toiture AS IceSol	Stock Th	Bois Th	PAC GLN Th
<b>Efficacité énergétique</b>							
Efficacité chauffage		+++	++	+++	-	+	+++
Efficacité ECS		+	++	+++	-	+	+
Couverture EnR ECS		+	+	++	-	+++	+
Consommation énergétique primaire (Indice Minergie®)		+++	+	+++	-	+	+++
<b>Coût d'investissement et d'exploitation</b>							
Investissement total	CHF	1 350 000	560 000	1 230 000	-	990 000	500 000
Subventions	CHF	370 000	60 000	370 000	-	170 000	60 000
Coût annuel amortissement et exploitation	CHF/an	91 000	50 000	88 000	-	86 000	44 000
Coût annuel pour l'énergie	CHF/an	54 000	70 000	51 000	-	77 000	132 000
Coût annuel total	CHF/an	145 000	120 000	139 000	-	163 000	176 000
<b>Compatibilité avec variantes enveloppe</b>							
Compatibilité avec variante A (SIA380/1)		Oui	Oui	Oui	-	Oui	Oui
Compatibilité avec variante B (Minergie-Audit)		Oui	Oui	Oui	-	Oui	Oui
Compatibilité avec variante C (Minergie-P)		Oui	Non	Oui	-	Non	Oui

Figure 26: Cost comparison of the heat production systems alternatives in the frame of a preliminary study for the La Cigale project (Source: BG Ingénieurs Conseils SA)

Due to best cost/performance ratios it was decided to go for the high quality building renovation alternative (meeting Swiss Minergi-P building standard) combined with the "IceSol" thermal energy supply concept. As can be seen in Figure 26, the IceSol scenario (scenario three) shows a) high energy efficiency, b) has 2nd highest cost in terms of investment but 2nd lowest cost in terms of annual costs and c) is fully compatible with any refurbishment alternative.

*Which stakeholders were involved in the project?*

The housing cooperative, the estate corporation and a Swiss credit bank.

*Which resources were available before the project?*

The available local resources are: solar, geothermal, wood, gas and lake water. However, none of the available resource did represent a specific opportunity or was to be fostered more than another (except maybe solar heat).

*Who (what) were drivers and who (what) were opponents (barriers) – and why?*

The main driver was the architect of the project which implication was not only oriented towards structural aspects and aesthetics, but also towards energy efficiency. He made happen that the question of heat production, one of the main trigger for this project, remained a central point of discussion. Therefore, energy advisors were involved from the beginning.

Another key driver was that the estate corporation was convinced of the project objectives.

*What have been the main challenges regarding decision finding?*

To promote an innovative system never tested at such scale, and to reach a plausible cost estimate. Another condition was to ask for a turnkey project guaranteeing energy performances of the system.

*What was finally the crucial parameter for go /no-go decision?*

The final decision was based on the cost/performance ratio. Here the Swiss standard Minergie-P was chosen as building standard, which also strongly influenced the design of the heat supply system. There was also a strong will of the owners to go for the most environmental friendly refurbishment solution, as long as it remained within an acceptable financial frame. The whole refurbishment project proves to be also financially attractive on a mid-term base. High savings in CO2 taxes are amongst the most important monetary drivers for the realization of the La Cigale project.

#### **Financing issues:**

*What have been the main challenges / constraints regarding financing?*

For both the Vermont and Vidollet buildings, the heating system represents a total investment of ~1.83 M CHF (1.68 M EUR as of June 2017), incl. dismantling the old technical heating installation, incl. adaptation on heating distribution piping to connect on the new heating system, incl. supply and rental of mobile oil boilers during the works in the heating plant. Where the total building refurbishment project cost is reaching 20 M CHF (18,4 M EUR as of June 2017). The main challenge was rather to justify a high standard of refurbishment and, along with it, an adequate and innovative heat production system. In other words, the selected advanced heating system would probably not have been considered without the strong motivation for an efficient refurbishment solution. In case of a less « ambitious » refurbishment, it is most probable that the solution using a combination of a gas boiler + a solar thermal system for domestic hot water pre-heating would have been installed.

*Which business model applies to the project?*

The project is profitable. The financial operation has been a success. The apartment rental cost was only increased by less than 50 EUR/room/month. This results from a combination of higher rating costs and lower energy charges.

#### **Technical issues:**

*What have been major technical challenges / constraints regarding system design?*

Designing the selected heating system at this scale was a premiere. The calculation tools were therefore not ready to handle the project and a certain additional work and care. The estimate the hourly profile of heat demand (DHW and heating) was also a challenge, as the norms and real figures are always different. The design includes a certain margin, however in order not to penalize the system efficiency due to oversizing; a small gas boiler was installed.

**Description about the design approach applied:**

*Which design targets have been set and why?*

The designed heat production system was targeting the following shares of energy sources: 29% of direct use of solar heat, 52% of indirect solar heat (through HP), 17% electricity at heat pump and 2% gas. Those targets are related to the system itself and the dimensioning of the storage tank. The measurements made over the last 12 months (2nd year measurements from 24.06.2015 to 23.06.2016) indicate a ratio of 24% electricity consumption (heat pump + all components of the heating plant using electricity), 6% gas and 69% (13% direct, 56% indirect) of the energy comes from the thermal solar panels. These results are slightly worse than the forecast. The main reason is the domestic hot water consumption that is definitely higher than the consumption profile which was taken into account for the dimensioning of the project. A way to overcome this would be to install additional solar collector area, and/or to install heat pumps with better COP values, and/or installing heat pumps able to get high temperatures at the condensator side even with temperatures far below zero on the evaporator side.

*What were the decision steps to lead to the retained solution?*

First to decide on the refurbishment standard. Here the retained solution was motivated by the possibility to reach high energy performance and to transform old balcony into non-heated loggias with a good financial balance of the project (with low impact on the renters). Once the refurbishment standard chosen, the realized IceSol solution was in competition with two other scenarios: heat pump coupled to geothermal energy and heat pump coupled to lake water.

The solution using lake water had a big disadvantage: the lake water grid has been installed by the local energy provider (SIG), meaning that each kWh of heat extracted from this grid has a cost. The owners of La Cigale did want to be as much as possible independent from energy costs. Therefore, this solution was abandoned.

The alternative with boreholes was also discarded for the following reasons:

- It was a little more expensive than the retained "ICESOL" system.
- Drilling boreholes in an urban environment brings a lot of acoustic disturbance. The people living in La Cigale lived in their apartments during the refurbishment. Thus it was crucial to reduce disturbances as much as possible.

*Which tools have been used during the design phase?*

Energie Solaire SA has developed a simulation tool in Excel over the last years. It is an hourly based simulation model. It uses climate data from Meteonorm extracted from Polysun. This simulation model was compared with field measurements on ICESOL systems and give good correspondence. Energie Solaire SA also developed a template for the ICESOL system in Polysun. However at that time, this simulation gave a worse correspondence compared to field measurements. It is, by the way, the aim of the company to improve the Polysun template to get more reliable results also with the Polysun simulation software.

#### **4.6.4 Lessons learned (barriers and success factors)**

*What have been major success factors?*

Strategically, the involvement of different stakeholders (housing cooperative's representative, architect in charge of the project, engineering companies) from the very beginning turns out to be very productive.



The architect played a key role as he addressed the future building heating systems together with renovation measures from the very beginning.

*What have been major bottlenecks?*

The technology readiness level at such scale was a risk. Another important constraint was to deal with an inhabited site to execute the works (bringing the nuisance level to a strict minimum) and to complete construction works within 12 months.

This retrofitting project implied also to deal with the building given configuration. A condition was to plug the new heating system on the existing distribution network. Another difficulty was in terms of space availability where the access to the technical room was not adequate to receive the selected heat production units.

*What are the major lessons learned?*

That an old building from the '50 can be converted into an exemplary building through energy efficient, and financially viable, retrofitting concept and heat production system.

*What should be transferred from this project?*

To perform at the same time the refurbishment works and the change of the heat production system.

To disseminate this success story for its replication (compared to other projects oriented towards new constructions).

#### **4.6.5 Summary**

The project of "La Cigale" in Geneva is a very successful example for high-quality building renovation combined with an innovative modernization of the heating system. As an important driver, the responsible architect pushed the development of an integral building renovation and heat supply concept from the very beginning and extensive pre-evaluation studies were carried out in an early project phase. For decision finding on which studied options to realize, overall energy efficiency as well as annualized costs were considered to be more important parameters than (initial) investment costs. This approach led to the following results:

From 2016 measurements (second year of operation) renovation of the building envelope decreases thermal energy demand by 55% (building complex meets low energy standards today) and moreover, around 69% of the total building thermal energy demand is covered by 1,740 m<sup>2</sup> roof-integrated unglazed solar thermal collectors. This high solar fraction is achieved by means of a heat supply concept that combines compression heat pumps, latent ice storages and solar thermal in a very smart way: Depending on the season of the year space heating and domestic hot water preparation is either provided by solar thermal only, or a combination of solar thermal with heat pump operation including charging / discharging of the ice storage is applied. A small natural gas source provides peak and backup capacity.

## 4.7 Solar-assisted mountain holiday resort “Reka Feriendorf” in Naters, CH

### Authors:

Gabriel RUIZ	CREM	<a href="mailto:gabriel.ruiz@crem.ch">gabriel.ruiz@crem.ch</a>
Fabien KUCHLER	Lauber IWISA AG	<a href="mailto:fabien.kuchler@lauber-iwisa.ch">fabien.kuchler@lauber-iwisa.ch</a>



Figure 27: Aerial view on the “Reka Feriendorf” in Naters, Switzerland (Source: Lauber IWISA AG)

**Project fact box:****General information:**

Location: Mountain holiday resort in Naters, CH, Switzerland  
 Urban scale of area: 1.2 ha  
 Residents in the area: Total capacity = 224 people  
 Building characteristics: 78% apartments, 10% offices, 12% services and pool  
 Owner: 50% Swiss Travel Fund (Reka) Cooperative), 50% municipality of Naters

**Specific information:**

Heated floor area: 6.646 m<sup>2</sup>  
 Electrical energy consumption: 115 MWh/a (measured 2016) / 269 MWh/a including heat pump  
 Thermal energy consumption (incl. network heat losses): 562 MWh/a (measured, 2016)  
     Useful thermal energy demand (heat sold): 468 MWh/a (measured, 2016)  
     Network heat losses: 94 MWh/a (16.7%, measured, 2016)  
 Heating grid trench length: 300 m  
 No. of building substations: 9  
 Supply/Return temperatures: 3 levels : 50..65°C for DHW | 35°C for heating | 25°C return  
 Energy supply system:  
     3x72kW electrical heat pump for space heating + 12m<sup>3</sup> technical tank,  
     1x47kW electrical heat pump for DHW + 8m<sup>3</sup> tank,  
     31 ground probes (150 m deep) for seasonal energy storage  
         ~273 MWh/a extracted, ~270 MWh/a injected (measured, 2016)  
     Waste water energy recovery system  
         ~135 MWh/year extracted (measured, 2016)  
     671 m<sup>2</sup> uncovered PVT collectors (corresponding to around 450 kWp,th and 102.5 kWp,el)  
     487 m<sup>2</sup> PV panels (corresponding to around 70.5 kWp,el)

**Specific information about the solar part:**

Annual solar energy yield and solar fraction:  
     ~218 MWh/a of direct solar generated heat (measured value)  
         Solar (thermal) fraction: 39% (referring to total heat demand incl.losses)  
         Specific solar thermal energy yield: 325 kWh/(m<sup>2</sup>-a)  
     139 MWh/a electricity form PV and PVT (measured, 2016)  
         Solar (electric) fraction: >100% of electrical demand excl. heat pump and 52%  
         incl. heat pump  
         Electric efficiency PVT collectors: 809 kWh/kWp (measured, 2016)  
         Electric efficiency PV collectors: 793 kWh/kWp (measured, 2016)

**Economic figures:**

Total building project cost (incl. energy system): ~25 M EUR; (excl.8% VAT)  
 Total energy system project cost\*: ~2.04 M EUR; (excl. 8% VAT)

Ground probes	408 k€ (20 %)
Heat pumps, technical needs, waste water energy recovery	489 k€ (24 %)
PV panels + PVT collectors	979 k€ (48 %)
Heating grid, others, engineering	163 k€ (8 %)

[\*] Exchange rate (CHF → EUR) considered. Base date: 01.01.2014 ([www.oanda.com](http://www.oanda.com), accessed on 01/2017)

#### 4.7.1 Introduction and description

“Reka Feriendorf” is a holiday resort located at 1,300 meters above sea level in Kanton Wallis, Switzerland and was inaugurated in winter 2014. The resort comprises 50 apartments, an indoor pool as well as childcare infrastructure and offices.

Total heated floor area amounts to 6,646 m<sup>2</sup> and the planned thermal energy demand (including electrical, heat and system losses) is 670 MWh/year (562 MWh measured in 2016). The high-quality buildings are equipped with heat pumps, PVT collectors as well as PV panels. The energy supply concept also includes underground heat storage and heat recovery from waste water. On an annual basis, about 77% of the thermal energy demand and 100% of the electrical energy demand (excl. heat pumps) is provided on site.

#### 4.7.2 Technical description of the concept and innovative approaches

The energy supply concept consists of two separate networks with centralized storages: one low temperature dedicated to heating purposes (35°C network), the second, high temperature (65 °C network), is for the domestic hot water. Each separated heating network is supplied by an own heat pump optimized for the respective temperature levels needed (Figure 28).

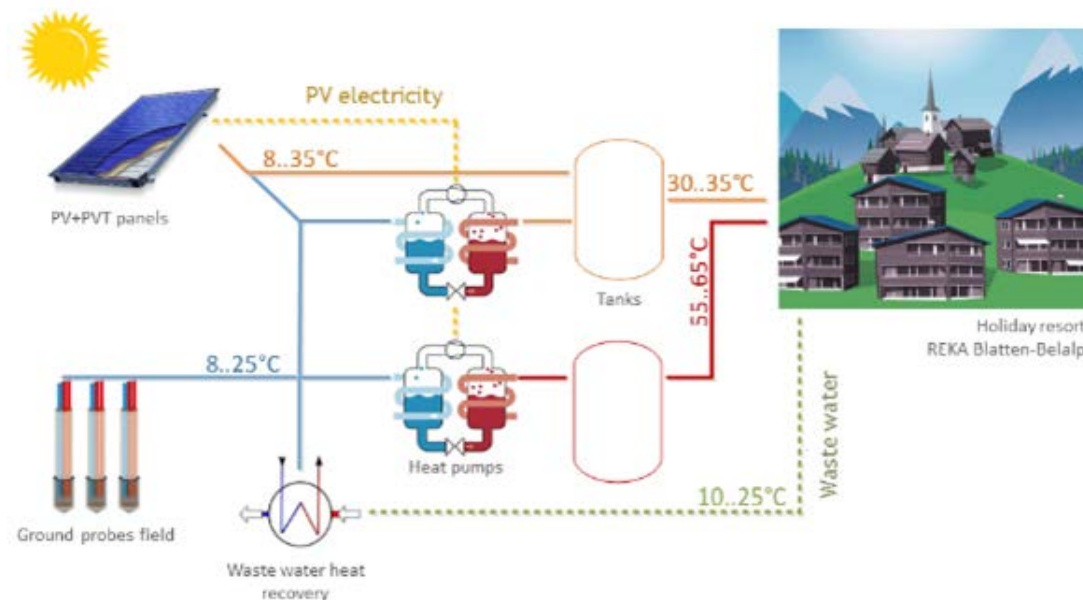

Figure 28: Principle diagram of the “Reka Feriendorf” heating system (Source: Reka AG 2015)

#### Operating principle:

On sunny days, thermal energy from the PVT collectors is directly used to meet space heating and domestic hot water demands (operating mode 1). In case the solar thermal collectors are not able to meet the demand, compression heat pumps help to boost the temperature to the required level (operation mode 2). Electricity produced by the hybrid collectors (PVT) may be directly used for heat pump operation or is transferred to the electricity grid. In addition to the hybrid PVT collectors conventional PV panels (reaching a sum of 173 kW<sub>p,el</sub>) are installed to meet, in total, more than 50 % of the annual electricity demand of the entire holiday resort.

Besides of the PV, PVT and compression heat pump combination the use of seasonal borehole thermal energy storage might be highlighted. The storage consists of 31 ground probes with a length of 150 m and is used in summer to store excess solar thermal generated heat. In the heating season, the borehole thermal energy storage act as heat sink for heat pump operation and hence solar thermal energy stored in summer helps to operate the heat pumps at higher efficiencies in winter. In

addition, a waste water heat recovery system is installed as additional heat source for heat pump operation.

The heart of this innovative system is the main regulation device comprising of a hydraulic control valve and the related control rules managing the energy distribution and its sourcing strategy. The control settings were developed by the engineering office Elimes.

The project was awarded the Swiss solar 2015 award.

#### 4.7.3 Decision and design process

*The following questions and answers aim at understanding the context (political, urban, energy) and the pre-design steps that led to the retained solution.*

##### **General / organizational issues:**

*Why was this project initiated, to answer which need?*

The project was initiated upon the Reka Company' ambition of creating a new holiday resort. In its ambition, Reka underlined the necessity to integrate an eco-friendly concept.

*Which stakeholders were involved in the project?*

- Swiss Travel Fund (Reka) Cooperative: Owner, investor and operator
- The Municipality of Naters: supporting the project on its territory
- Elimes: engineering office in charge of the overall project planning
- Swiss Federal Office of Energy (SFOE): providing some financial support

*Which resources were available before the project?*

Solar, wood (although not available in the direct surrounding), geothermal (but not enough to cover the whole energy needs) and oil (imported).

*Who (what) were drivers and who (what) were opponents (barriers) – and why?*

The driver was the Reka Company willing to invest in a new holiday Village. The local authorities did play a crucial role from a political perspective as they fully supported the project from its beginning.

Although the whole project represented a technical challenge, no important oppositions from public/private bodies were faced.

*What have been the main challenges regarding decision finding?*

For the engineering office to convince Reka about the innovative and adequate technical solution in terms of heat supply and building envelope. In fact, if the building typology was set by the project owner, the related building energy standard was left open to the engineering office. This allowed the definition of the insulation and ventilation standards in order to fit the retained energy production and supply concept.

*What was finally the crucial parameter for go /no-go decision?*

The financial aspects, i.e. to convince the project Owner to go for a higher investment balanced by low annual costs (total cost of ownership) compared to other alternatives.

##### **Financing issues:**

*What have been the main challenges / constraints regarding financing?*

To accept a concept with higher investment becoming profitable at long term (compared to a conventional system with oil boilers investment costs for the realized concept are around ten times higher). In order to promote a sustainable solution, the project Owner also accepted that the price of



final energy could be of more than 10%<sup>8</sup> higher than the actual market price for an oily boiler system (benchmark scenario).

To obtain subsidies from public bodies with an innovative project which cannot, by nature, exactly fit some established programs.

*Which business model applies to the project?*

The target was to propose a fair price of energy sold throughout the lifetime of the energy system's components. The energy system itself is not meant to optimize profits. The overall business model was oriented towards generating profit through the holiday resort activities.

**Technical issues:**

*What have been major technical challenges / constraints regarding system design?*

To develop and implement a control system for the efficient operation of all combined energy system components. Especially control of the heat pumps for highest COP's was challenging.

**Description about the design approach applied:**

*Which design targets have been set and why?*

Reka's commitment of developing sustainable holiday resorts implied an energy supply concept for the Village with an important focus use of renewable energy sources. The condition was also set as being economically as interesting as using a traditional oil firing system.

*What were the decision steps to lead to the retained solution?*

A major challenge in the design process was to find the right balance (in terms of cost, energy and climate indicators) between building insulation standard and high share of renewable energies in the energy supply. An additional special issue to be treated was the location of the holiday resort (high altitude of 1500x meters) as well as the seasonal occupation. Next, architectural and landscape integration represented an important decision criterion.

In order to find an appropriate solution, four technical concepts were defined by Lauber IWISA AG together with their engineering branch Elimes for further investigations. Each option was evaluated considering four criteria (investment cost, annual operating cost, share of renewable primary energy, CO2-emissions):

- 100% oil fired (as benchmark)
- Wood pellets boiler
- Solar thermal collectors + seasonal underground storage + heat pumps
- PVT collectors + seasonal underground storage + heat pumps

*Results of investigations and decision finding:*

The cost comparison of the 4 studied scenarios is presented in Figure 29 below. It appears that the realized concept (the 4th scenario) requires a much higher investment compared to the other concepts. The difference between the 3rd and 4th scenario illustrates the additional costs of PVT collectors. This higher investment cost is however balanced by the lower running costs (energy & maintenance).

---

<sup>8</sup> 10% corresponds to a so-called « psychological limit » considered as reasonably acceptable to a standard investor for promoting green solutions (marketing, sustainability,... )

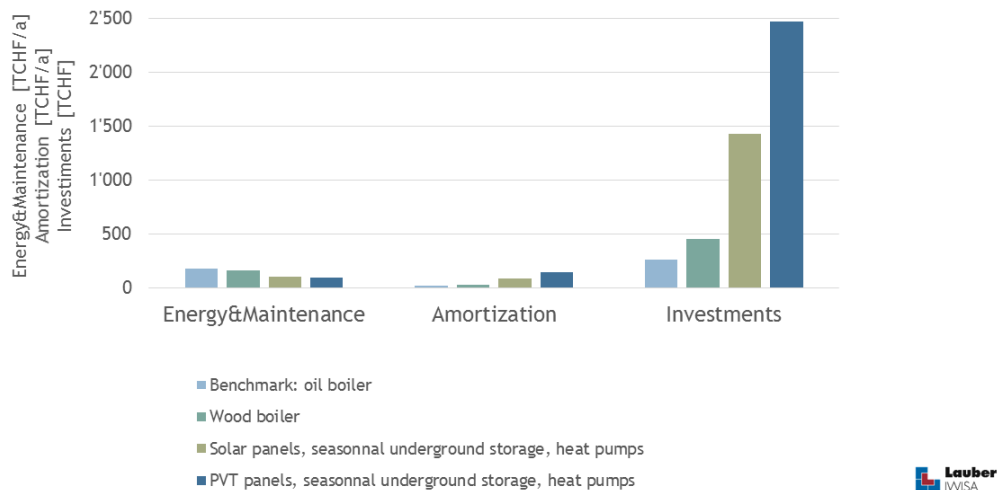

Figure 29: Cost comparison of the 4 studied scenarios. (Source: Lauber Iwisa, 2014)

In terms of total specific energy costs, Figure 30 below shows two main aspects:

- The retained solution (4th scenario) cost more than 10% higher, compared to a system using oil boiler (benchmark scenario), which proves the willingness of the investors and the owner to go on a green solution.
- The decrease of the oil price since the project study is not contributing to promote renewable sourced solutions from the perspective of the final price of energy (and especially concerning the retained scenario).

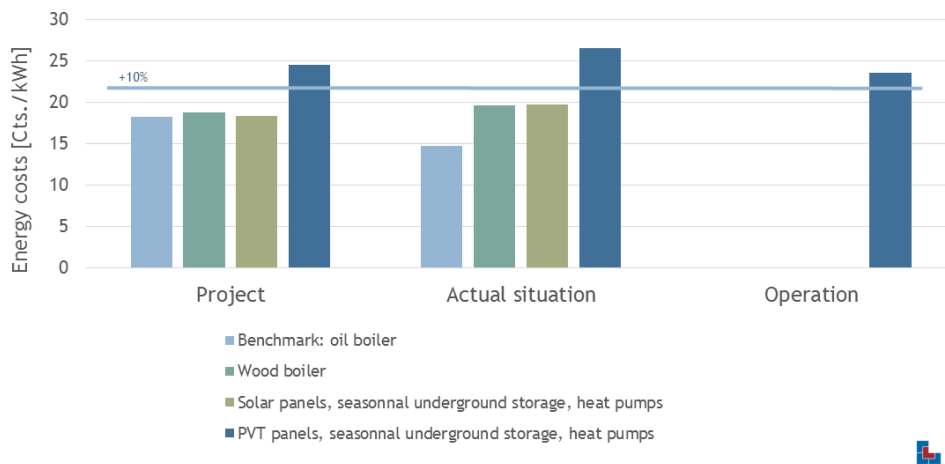

Figure 30: Comparison of the total specific energy costs of the 4 studied scenarios, with project situation representing year 2014, actual and operation situation representing 2016. (Source Lauber Iwisa, 2017)

Finally, the 4th scenario was chosen, despite a less profitable business case. The final decision was driven by the will of the Owner to build an exemplary energy-efficient holiday resort.

*Which tools have been used during the design phase?*

- "Polysun" for dynamic simulation.
- "AutoCAD" for static measures of thermal needs (building envelope)
- Own valuation tools for financial analysis.

*What have been the main challenges in the design phase?*

To run an iterative process leading to find the best solution (in terms of the above mentioned criteria for decision finding)

### *What have been the most crucial interfaces?*

The relationship between the engineering office (establishing the concept) and the investor (project Owner) to agree on the retained solution.

#### **4.7.4 Lessons learned (barriers and success factors)**

##### *What have been major success factors?*

- The trusting relationship between the project owner (Reka) and the engineering office on the technical concept and the cost estimate.
- The homemade control algorithms of the system's main regulation device.
- The system works beyond expectations, where 77% of the thermal energy demand (incl. heat losses) is sourced from renewables (solar + environment), where 100% of the required electrical energy (excl. heat pumps) is covered by PV+PVT collectors, and where the electrical demand of the heat pumps is partly supplied by PV panels.
- Importance to estimate the project costs including the operating costs, and to have a strong financing capacity.

##### *What have been major bottlenecks?*

- Investing capacity requested for the retained energy system.
- The risk taking, actually supported by the engineering office in terms of risks management, and by the project Owner in terms of risk acceptance.

##### *What are the major lessons learned?*

- The necessary cooperation between the client, the architects, and the energy planner
- The need of flexibility during the project management
- A need for open and transparent communication between all participants
- A close collaboration between the planning and the construction

##### *What should be transferred from this project?*

- The applied and proven energy concept
- The feasibility (technically and economically speaking) of reaching ~80% energy independency with renewable and local resources
- The trade-off between high performance envelope and efficient energy system. This aspect gave birth to a Swiss research project "OSCARS" financed by the SFOE.

#### **4.7.5 Summary**

Awarded by the Swiss solar 2015 award, the solar-assisted mountain holiday resort "Reka Feriendorf" shows an extremely high level energy independency with more than 80% of the total energy demand (electrical and heat incl. heat losses) covered by renewables and local resources. The main innovation in the energy system is the main regulation device comprising a hydraulic valve and its control rules. To achieve such high level of performance, the energy system is based on different kinds of solar technology (PV panels and PVT collectors), multipurpose water storage and heat pumps coupled to ground probes. Economic studies showed that a major bottleneck to the realization of the project was the high initial investment costs. However, a good collaborative and trusting relationship between all stakeholders as well as the strong will of the Owner to build an exemplary energy-efficient holiday resort finally led to the realization of the project. Finally, the system works beyond expectations.

## 4.8 Solar-assisted urban quarter “Buchsee-Köniz” in Berne, CH

Author:

Christine WEBER

BKW AG

[christine.weber@bkw.ch](mailto:christine.weber@bkw.ch)



**Figure 31: Aerial and schematic view of the solar-assisted urban quarter “Buchsee-Köniz” in Berne, Switzerland.** (Source: Kommunale Richtpläne Energie © Amt für Umweltkoordination und Energie des Kantons Bern, Google Maps)

**Project fact box:****General information:**

Location: **Municipality of Köniz (canton of Berne) in Switzerland**  
 Urban scale of area: **130 ha**  
 Population in the area: **~4,000**  
 Building mix in the area\*: **70% SFH & MFH, 30% non-residential (school & retirement home)**  
 Consumer mix in the area\*\*: **30% small consumers, 70% medium consumers**  
 Plant owner (public or private): **private (planned owner BKW, no execution)**

**Specific information:**

Heated floor area: **Unknown**  
 Final thermal energy demand (incl. thermal losses): **7,090 MWh**  
 Useful thermal energy demand (heat to be sold): **6,490 MWh**  
 Network heat losses: **600 MWh/a (8.5%)**  
 Heating grid trench length: **1,600 m (feed + return pipes)**  
 No. of consumer substations: **16**  
 Supply/Return temperature levels: **Winter: 88/60 °C / Summer: 75/50 °C**  
 (Thermal) energy supply technologies: **Wood-chip burner (1.200 kW), Oil boiler (2.800 kW), Solar thermal (~ 560 kWp,th)**

**Specific information about the solar thermal part:**

Solar thermal collector area: **869 m<sup>2</sup><sub>gross</sub> / 799 m<sup>2</sup><sub>aperture</sub>**  
 Thermal energy storage: **70 m<sup>3</sup> pressurized steel tank**  
 Annual solar energy yield: **361 MWh**  
 Solar fraction: **5 % (based on final thermal energy demand)**  
 Specific annual solar energy yield: **415 kWh/m<sup>2</sup><sub>gross</sub> / 451 kWh/m<sup>2</sup><sub>aperture</sub>**

**Economic figures (Version 1: Basic layout + roof D – see description in chapter 4.8.2)**

	<i>CHF</i>	<i>Euro (JAN2016)</i>
<i>Solar installation</i>	<i>574'000</i>	<i>528'080</i>
<i>Wood specific parts (wood chip burner)</i>	<i>790'750</i>	<i>727'490</i>
<i>Peak demand parts (oil boiler)</i>	<i>175'000</i>	<i>161'000</i>
<i>Hydraulics (incl. heat transfer station + storage)</i>	<i>566'000</i>	<i>520'720</i>
<i>Electricity + sanitary parts</i>	<i>180'000</i>	<i>165'600</i>
<i>Construction + site development</i>	<i>1'227'000</i>	<i>1'128'840</i>
<i>Heating Grid (incl. additional solar pipes)</i>	<i>1'680'000</i>	<i>1'545'600</i>
<i>Personnel fees + additional costs</i>	<i>15.00% 778'913</i>	<i>716'600</i>
<i>Reserve</i>	<i>10.00% 597'166</i>	<i>549'393</i>
<i>Additional costs</i>	<i>50'000</i>	<i>46'000</i>
<b><i>Total incl. Internal and corporate labour</i></b>	<b><i>6'618'829</i></b>	<b><i>6'089'322</i></b>

\* SFH: single-family home; MFH: multi-family home, AB: apartment block

\*\* Small consumers (SFH + MFH): <80 MWh/a, Medium consumers (AB, schools, etc.): 80-800 MWh/a, Large consumers (industrial consumers, hospitals, etc.): >800 MWh/a



#### 4.8.1 Introduction and description

The municipality of Köniz (canton of Berne) in Switzerland is one of 50 "energy cities" /1/ in the country. Based on specific requirements of the federal energy strategy 2050, the municipality holds the GOLD energy label. This means that diverse measures regarding energy efficiency and implementation of renewable energy generation are taken and road mapped.

Starting point for the solar part of the feasibility study was a current project in development for a wood-driven district heating grid. As BKW supports innovative and ecological case studies and projects, an extended case study was carried out.

Thus, the existing project was expanded by an assessment for a solar installation on the roof tops of the Köniz primary school buildings, owned by the municipality. This school area had already been chosen as potential site for the initial district heating central.

#### 4.8.2 Technical description of the concept

The overall system is a wood-driven district heating grid with solar assistance. The assessed area is an urban quarter in the canton of Berne, the municipality of Köniz. The heating central was planned to be installed on the premises of the Köniz primary school. The heat-supplied buildings were planned to be the school buildings and surroundings, mainly residential multi-family houses, an elderly home and some small enterprises. The bigger multi-family houses are administered by some bigger real estate companies. The main components are:

- Wood-chip burner
- Oil burner
- Solar thermal system
- District heating grid

Three different system layouts were economically evaluated, based on the available rooftop area as seen in Figure 32. A profound business case analysis was carried out for **Version 1 (Basic layout + roof D)** as this was the most feasible option regarding size, heat demand and costs.

1. Basic: Roofs A + B and heating central → in sum, 679 m<sup>2</sup> gross collector area
2. **Version 1: additionally roof D** → in sum, 869 m<sup>2</sup> gross collector area
3. Version 2: additionally roof E1 + E2 → in sum, 1.262 m<sup>2</sup> gross collector area

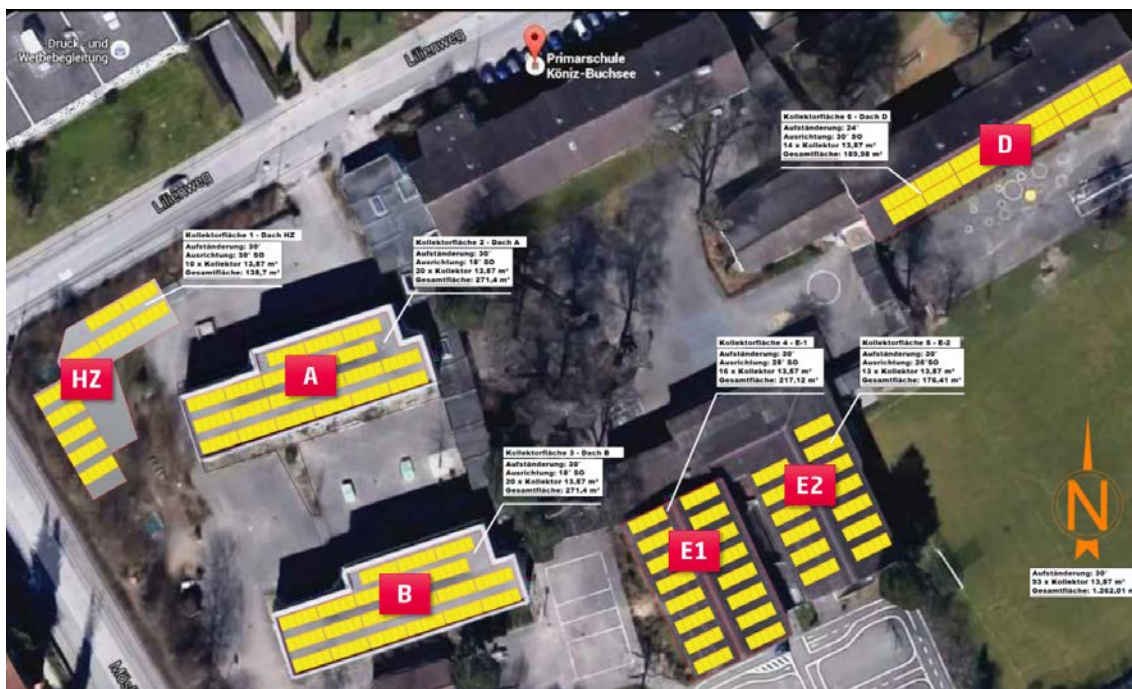
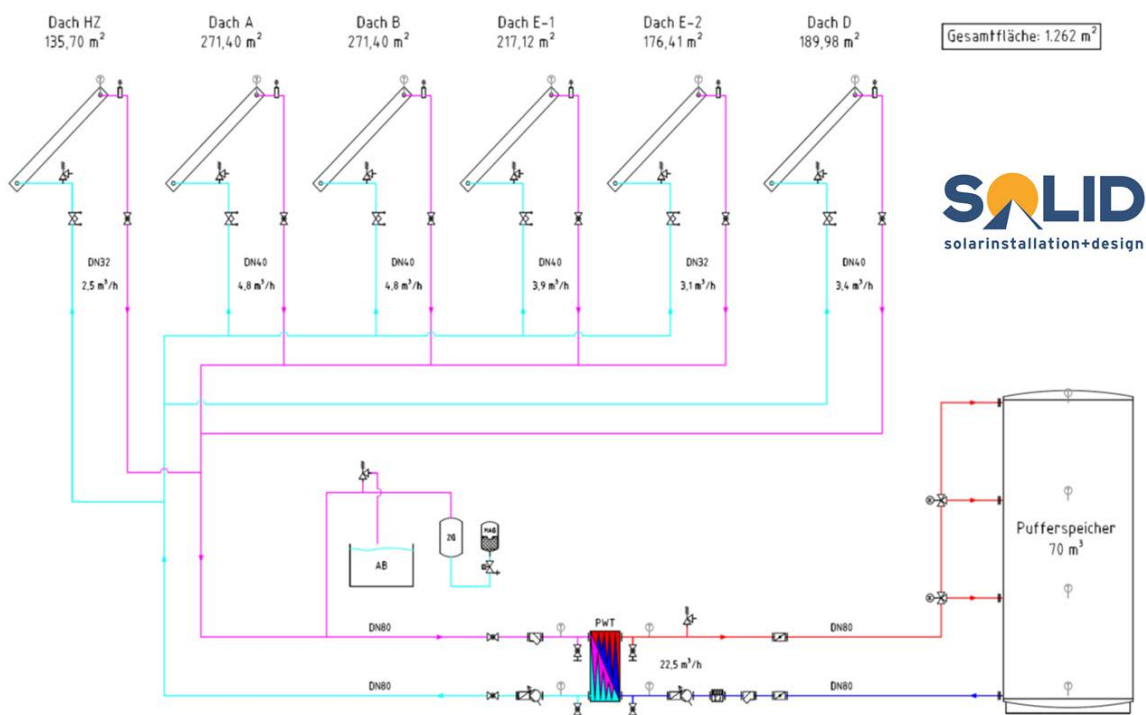

Figure 32: Different roof area options (Source: BKW, 2016, Google Earth)

In Table 1 next, feasibility study results for all three investigated options are summarized.

**Table 1: Summary of feasibility study results (Source: BKW, 2016)**

Version	Basic	Version 1	Version 2
<b>Solar installation</b>			
Gross collector area (m <sup>2</sup> )	679	869	1.262
Solar heat production (MWh/a)	280	363	505
Specific heat production (kWh/m <sup>2</sup> )	415	410	400
<b>Solar fraction (%)</b>	<b>4.3</b>	<b>5.6</b>	<b>8</b>
<b>Economics</b>			
Investment costs per m <sup>2</sup> (CHF) (Euro)	766 (715)	703 (657)	680 (635)
Heat price, <i>only for SOLAR</i> (CHF cents/kWh)	12.5	12.9	
<b>First feasibility study results</b>	<b>24</b>	<b>24.5</b>	<b>23</b>



**Figure 33: Hydraulic scheme of the proposed heat supply system for the urban quarter "Buchsee-Köniz"** (Source: S.O.L.I.D. in /2/) Note: this schematic refers to the largest possible variation (version 2).

Evaluation criteria of the individual version were based on economic and technical feasibility.

It was decided to have a profound economic analysis for **version 1**, because this version was the most feasible option regarding size, heat supply and costs. **Version 2** had one major drawback: the rooftops **E1** and **E2** are old and covering a gymnasium. They need to be refurbished in five years' time. Therefore, this was not a realistic option for the present project.

For the economic feasibility, the heat sales quantity is crucial. In general, several key customers need to sign the contracts. As one of the key customers did not commit to the project, it was stopped. The business case was negative. Some adapted options were assessed but none is planned to be carried out.

#### 4.8.3 Decision and design process

*The following questions and answers aim at understanding the context (political, urban, energy) and the pre-design steps that led to the retained solution.*

**General / organizational issues:**

*Why was this project initiated, to answer which need?*

The goal was to assess solar heat prices at larger scale. Starting point for the solar part of the feasibility study was a current project in development for a wood-driven district heating grid.

*Which stakeholders were involved in the project?*

- Tender phase: Municipality & engineering office
- Project development phase: BKW & engineering office, potential customers (inhabitants, municipality, and commerce)
- The solar assessment was managed by: BKW, engineering office, solar planner

*Who (what) were drivers and who (what) were opponents (barriers) – and why?*

- The drivers: federal energy strategy and energy label for municipalities (a national program the refers to the federal energy goals; municipalities need to meet certain standards regarding energy efficiency and integration of renewables)
- The barriers: keep the costs as low as possible

*What have been the main challenges regarding decision finding?*

Evaluation of the right costs for Switzerland, because there do not exist similar installations. Large-scale solar thermal plants have only been built a couple of times. Therefore, the solar planners are not experienced for those specific designs and dimensioning process.

*What was finally the crucial parameter for go /no-go decision?*

Costs: one key customer did not want to connect to the grid. The business case was missing.

**Financing issues:**

*Which business model applies to the project?*

A contracting business model was applied.

**Technical issues:**

*What have been major technical challenges / constraints regarding system design?*

The space for the thermal heat storage was a limitation.

**Description about the design approach applied:**

*Which design targets have been set and why?*

General grid & wood boiler: heat density of the heating grid. For economic feasibility a threshold for heat density of 2,000 kWh per meter of heating trench length is necessary. Solar thermal installation: biggest collector area on available roof tops in short distance to heating central.

*What were the decision steps to lead to the retained solution?*

1. Starting point: existing feasibility study for wood-driven district heating grid
2. Solar: existing roof tops close to heating central
3. Room for (additional) heat storage in heating central
4. Cost assessment of different "roof options". Estimation of investment and heat costs in CHF/kWh
5. Probability of installation (roof tops E1+E2 are going to be renovated)

*Which tools have been used during the design phase?*

Polysun, Excel, Expertise

*What have been the main challenges in the design phase?*

For the solar eligibility: Assessment of roof usability (statics and age)

#### 4.8.4 Lessons learned (barriers and success factors)

*What have been major success factors?*

Involvement of experienced players and professional execution

*What have been major bottlenecks?*

- Costs: Main/key customers (high energy demand) compare to cheapest way of their heat supply. If prices differ strongly, they won't buy.
- Some political issues: One key customer did not want to have an arrangement with BKW.

*What are the major lessons learned?*

- If costs do not meet customer requirements, they won't buy.
- If potential customers have political constraints, they won't buy.

*As a consequence, which framework conditions would be needed for a successful business case?*

- Lower costs
- CO<sub>2</sub>-fees
- Obligations to use renewable energy

*What should be transferred from this project?*

Currently, costs for conventional (oil, gas) heat production is too low for solar to compete with. This might change in due time.

Decision makers and heat customers are referring to today's pricing and the majority takes decisions based on current economic conditions.

Political decision makers are willing to make a change, but usually do not have the means to force people to make higher investments in costly technologies. This could only be the case for totally new settlement areas. Those are rare.

Solar-assisted district heating is an option, even with Swiss pricing. This needs further capacitation of professionals and/or involvement of external expertise. Therefore, national success stories are needed.

#### 4.8.5 Summary

The solar-assisted urban quarter of "Buchsee-Köniz" is probably a representative example of the difficulty to enforce solar thermal system installation. Despite a high upfront effort for the assessment of the wood-driven district heating grid and additional solar thermal assistance, the project was not executed. The project faced many bottlenecks that can be highlighted:

- The cost of the investment and final energy was too high.
- The lack of reference projects with solar assisted energy system and similar scale implies an increase of the risk for the project.
- The economic viability of a heat district is strongly linked to its heat density in the heating grid. In our case study, the planned heat demand decreased after the withdrawal of one key customer. Thus, the overall economic feasibility was negative. This also displays the high risk and fragility of the project development.
- The whole project setup already starts under difficult conditions: the first tender is done by the municipality, then they receive offers of companies that want to build a district heating system as contractor. The whole customer acquisition and economics risks then are located with the contractor that wins the tender. In general, the municipality supports the project with information for their inhabitants, but does not give any financial support or risk mitigation.

## 4.9 Solar-assisted urban quarter “Renens-CFF” in the suburb of Lausanne; CH

### Authors:

Martin Joly	Sorane SA	<a href="mailto:martin.joly@sorane.ch">martin.joly@sorane.ch</a>
Morgane Emery	Sorane SA	<a href="mailto:Morgane.emery@sorane.ch">Morgane.emery@sorane.ch</a>
Paul Bourdoukan	Sorane SA	<a href="mailto:Paul.bourdoukan@sorane.ch">Paul.bourdoukan@sorane.ch</a>

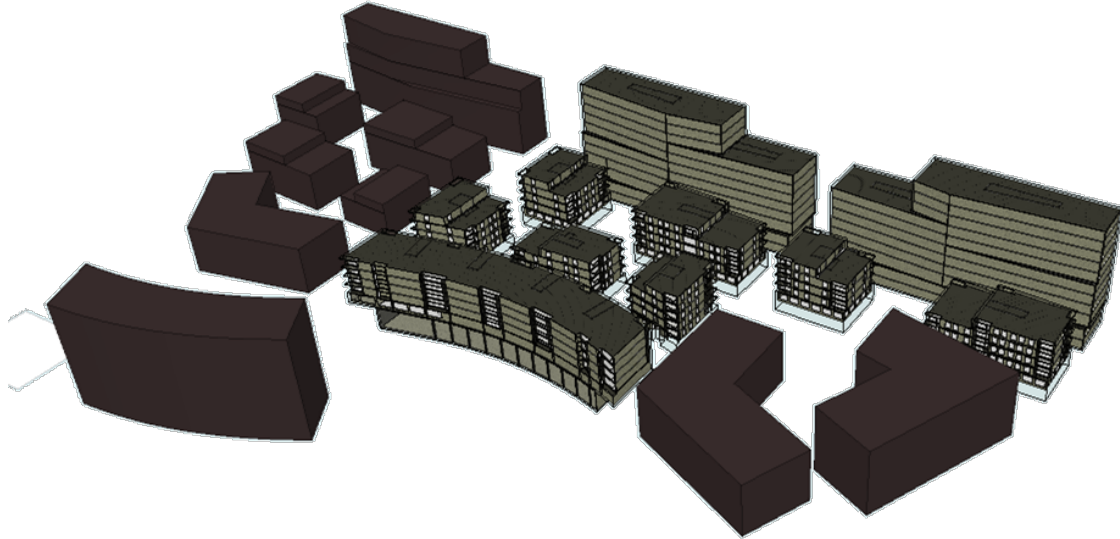

**Figure 34:** Schematic representation of the urban quarter “Renens-CFF” in Renens, Switzerland. (Source Sorane SA with Ida-ICE simulation output)



**Project fact box:****General information:**

Location: **Urban quarter "Renens-CFF" in the suburb of Lausanne, Switzerland**

Urban scale of area: **2 ha**

Population in the area: **~ 2500**

Building mix in the area: **residential – apartment block (37%), administration (48%), commercial (10%), catering (3%), school (2%)**

Consumer mix in the area: **Medium consumers (residential and administration)**

Plant owner (public or private): **Swiss federal board - Private**

**Specific information:**

Heated floor area: **41,297 m<sup>2</sup>**

Final thermal energy demand (incl. thermal losses): **797 MWh (design value)**

Useful thermal energy demand: **713 MWh (design value)**

Network heat losses: **Estimated ~ 84 MWh/a (11%)**

Heating grid trench length: **300 m**

No. of building substations: **3**

Supply/Return temperature levels: **110/50 °C**

Energy supply technologies: **District heating combined with heat pumps (power and energy system under discussion), Solar PV (333 kW<sub>p,el</sub>)**

**Specific information about the solar thermal part:**

Solar thermal collector area: **cancelled**

Thermal energy storage: **cancelled**

**Economic figures:**

Overall project budget: **≈ 175 M CHF (152 M EUR) incl VAT.**

**(Change rate 04.08.2017 : [www.oanda.com](http://www.oanda.com))**

**4.9.1 Introduction and description**

The project is composed of ten new buildings connected to an existing district heating network which is supplied by high shares (>60%) of renewable energy (mainly heat from waste incineration as well as from heat recovery) /1/. This settlement will be located in Renens in the suburb of Lausanne, along the railway. The buildings will house residential flats, administration, commercial surfaces, catering and school. The project shows a willingness to develop a sustainable project in term of

- Density and mix of population
- Architectural quality
- Promotion of alternative mobility
- Use of local resources
- Economic Viability
- Building Sustainability
- Social attractiveness

As the project is ongoing, the energy concept is currently under discussion (cooling and heat strategy, distribution and performance of envelop). Questions concerning the heat production and especially solar heat production are still discussed. As a function of the constraints the heat production changed and will probably still evolve. At the beginning of the project, there was a will to use solar thermal energy to produce domestic hot water. The planned energy system was thus to use a district heating connected to decentralized rooftop solar thermal energy system.

In Switzerland, restrictive cantonal legislation has to be applied in term of renewable fraction of energy needed, for the new or refurbished buildings. In Canton de Vaud, the new buildings have to fulfill the following constraints /2/:

- 30% of the needed energy for domestic hot water (DHW) have to be covered by renewable energy
- 20% of the needed electricity have to be covered by renewable energy
- 50% of the needed electricity for cooling and humidification have to be covered by renewable energy

For the project, it means that 20% of electricity needed in the building (without considering process consumption) has to be produced on site with PV panels. As a consequence, almost all available rooftop surfaces are used for PV panels, which clearly disadvantage solar thermal technology in this case.

#### 4.9.2 Technical description of the concept and innovative approaches

In the initial concept, integrated rooftop solar thermal energy system was coupled to district heating to produce hot water. The concept was based on the following points:

- Heat for domestic hot water and space heating is provided by a renewable-based district heating system. More than 50% of delivered energy is provided by waste burning or energy recovery system.
- Cold is produced on site
- Solar photovoltaic panels are used to provide renewable energy to cover a part of the needs for electric consumption.

#### 4.9.3 Decision and design process

*The following questions and answers aim at understanding the context (political, urban, energy) and the pre-design steps that led to the retained solution.*

##### **General / organizational issues:**

*Why was this project initiated, to answer which need?*

Swiss Federal board CFF owns land located next to city centers whose initial allocation does not correspond to current sustainable urban development objectives supported by the public authorities. The project objective is to develop a mixed neighborhood and create a quality living environment. The owner wants an exemplary project for sustainable development, especially in terms of energy.

*Which stakeholders were involved in the project?*

The Swiss board CFF is the owner of the lands and the buildings. As a federal organization, all the initial steps of the project were led in collaboration with public municipality. The project should correspond to German Sustainable Building Council label requirements (DGNB /3/).

*Which resources were available before the project?*

At the beginning of the project, no energy resources were available on the site. As the municipality is involved in the deployment of a heat district at the city level, it was highly suitable to connect the new neighborhood to the existing network. This district heating /1/ is considered as sustainable since more than 50% of the energy source is renewable (waste incineration).

*Who (what) were drivers and who (what) were opponents (barriers) – and why?*

The stakeholders agreed on the retained solution as it fulfilled all the objectives. Unfortunately, there was no objective or constrain in term of solar fraction but only in term of fraction of renewable energy. The solar energy system was thus in direct competition with renewable heat energy of the heat district and with solar PV electricity generation.

*What have been the main challenges regarding decision finding?*

During previous planning phase of the project, solar thermal system was foreseen as an energy source for the production of domestic hot water. The constraints on the energy system led to the choice of solar photovoltaic production to the detriment of the solar heat production.

*What was finally the crucial parameter for go /no-go decision?*

The available area for solar technology is one of the crucial parameter. In the case of a renewable heat district, the production of heat with solar thermal is not mandatory anymore. The priority is given to the photovoltaic panels which remain mandatory for renewable electric production.

**Financing issues:**

*What have been the main challenges / constraints regarding financing?*

In the case of façade-integrated solar thermal collectors, the cost of the solar thermal energy system represents a net and not mandatory additional initial investment cost.

**Description about the design approach applied:**

*Which design targets have been set and why?*

In term of legal constrains, we can list the following point:

- Thermal energy source for domestic hot water : >30% covered by renewable energy source
- Electric consumption of the building : >20% covered by renewable energy source
- Electric consumption for the cooling and humidification : >50% covered by renewable energy source

Moreover the German DGNB /3/ label is targeted for the project.

*What were the decision steps to lead to the retained solution?*

Initial principle for the energy system:

- Renewable heat district for heat and domestic hot water
- Solar thermal energy for domestic hot water
- Free cooling with boring hole

The heat district is renewable. The legal constraint regarding the fraction of renewable energy needed for the production of domestic hot water is thus fulfilled.

To cover the electric consumption of the building (20%) and the cooling (50%), a substantial surface of photovoltaic panel is required. As the rooftop area is limited, priority is given to PV panel as they are need to fulfilled the legal constrains. The energy concept changes during the project and the following system is currently retained:

- Renewable heat district for heat and domestic hot water
- Solar PV for electric demand (333 kW<sub>p,el</sub>)
- Cooling with heat pump and free cooling tower

*Which tools have been used during the design phase?*

In order to choose the energy concept, no specific tool was used. Decisions were taken as a function of legal constrains and initial objectives.

Nevertheless, energy flux simulations were preceded. The tools used to manage this work were:

- LESOSAI: calculation of the buildings annual consumption
- IDA-ICE: calculation on an hourly basis of the need for space heating
- Polysun : design of the system and calculation of the solar domestic hot water production
- TRNSYS: dynamic simulation of the energy system including solar production and storage.

#### 4.9.4 Lessons learned (barriers and success factors)

The energy system planned in the project is efficient in term of use of renewable energy. Nevertheless, solar thermal panel were rejected during the planning phase. The main factors that led to this decision were:

- The legal constrains
- The limited area on rooftop
- The additional complexity and investment cost of the solar thermal system

##### *Lessons learned:*

- When the heat district is considered as renewable, the solar thermal is in competition with the network
- Solar thermal energy system can easily produce the domestic hot water. In this situation, the heat district are not needed any more during summer time:
  - o Advantages for the consumer : during summer time, the consumer is almost independent from the heat district
  - o Disadvantages for the heat district: usually, the production of heat is not depending on the season and is rather constant. The heat produced during summer time this therefore lost in the heat pipe losses.
- In Switzerland, high fraction of renewable electricity is required. Solar PV technology are thus encourage to the detriment of solar thermal system.

#### 4.9.5 Summary

Swiss legislation is restrictive in term of use of non-renewable energy for buildings. Even if the rate is given, the type of renewable source can be chosen by the stakeholders. Most of the time, the energy sources are based on solar (PV and/or thermal), wood, heat pump or heat recovery energy systems. This case study shows an interesting example where renewable energy sources are competing against each other.

On a pre-project stage, solar thermal installations were planned to produce domestic hot water. This initial solution was finally not retained. The reason to that was on a one hand, the high renewable fraction of the heat district which was sufficient to reach the legal needed fraction of renewable, and one the other hand, the legal constraints in term of renewable electricity. To tackle this point, solar photovoltaic installations are currently retained.

As bottleneck to the installation of solar thermal we can list:

- The available area on rooftop is a limiting factor.
- When an existing district heating contains a high fraction of renewable resource, the heat coming from the district is directly competing with the solar heat.
- In order to meet legislative constraints, solar photovoltaic system was retained in the energy concept.

## 5 Literature References

In the following, link(s) to further project related information / publications, etc. are given for each case study described in the main text.

### Chapter 4.1: Solar district heating with seasonal storage in the city of Dronninglund, DK

/1/	SOLARHEATDATA.EU: <a href="http://solarheatdata.eu/">http://solarheatdata.eu/</a> , accessed on 01/2017
/2/	Annual financial report of Dronninglund fjernvarme 1/6 2013-31/5 2014 : <a href="http://www.drlund-fjernvarme.dk/media/2118511/2013-2014-Bestyrelsens-beretning.pdf">http://www.drlund-fjernvarme.dk/media/2118511/2013-2014-Bestyrelsens-beretning.pdf</a> , accessed on 01/2017
/3/	Dronninglund Solar thermal plant booklet: <a href="http://www.drlund-fjernvarme.dk/media/2710783/Brochure_Dronninglund_2015_booklet_ENG_web_.pdf">http://www.drlund-fjernvarme.dk/media/2710783/Brochure_Dronninglund_2015_booklet_ENG_web_.pdf</a> , accessed on 01/2017
/4/	SUNSTORE 3 – Phase 2 Implementation (final report for funding programme EUDP), PlanEnergi 2009, <a href="https://issuu.com/planenergi.dk/docs/sunstore-3-final-report.compressed">https://issuu.com/planenergi.dk/docs/sunstore-3-final-report.compressed</a> , accessed on 05/2016
/5/	Solvarme – Inspirationskatalog, Inspiration og erfaringer fra solvarmeanlæg i kombination med fjernvarme i Danmark by PlanEnergi for the Danish District Heating Association, Solar ERFA-group, 2017
/6/	Aftale af 13. november 2012 om Energiselskabernes energispareindsats, <a href="https://ens.dk/sites/ens.dk/files/EnergiKlimapolitik/aftale_energiselskabernes_indsats_af_13_november_2012.pdf">https://ens.dk/sites/ens.dk/files/EnergiKlimapolitik/aftale_energiselskabernes_indsats_af_13_november_2012.pdf</a> , accessed on 28/02/2017

### Chapter 4.2: Hybrid solar district heating in the city of Taars, DK

/1/	Bengt Perers, Simon Furbo, etc. Thermal performance of concentrating tracking solar collectors .DTU Report R-292.2013.
/2/	Aalborg CSP: <a href="http://www.aalborgcsp.com/projects/csp-plant-for-district-heating-in-thisted-denmark/">http://www.aalborgcsp.com/projects/csp-plant-for-district-heating-in-thisted-denmark/</a> , 2016.July.
/3/	Janne Dragsted, Simon Furbo. Solar radiation and thermal performance of solar collectors for Denmark. DTU report.No.r-275(UK).2012.
/4/	Arcon Sunmark: <a href="http://arcon-sunmark.com/products">http://arcon-sunmark.com/products</a>
/5/	Perers B, Furbo S, Tian Z, et al. Tårs 10000 m2 CSP+ Flat Plate Solar Collector Plant-Cost-Performance Optimization of the Design[J]. Energy Procedia, 2016, 91: 312-316.

### Chapter 4.3: Solar-assisted urban quarter “Salzburg-Lehen”, AT

/1/	<a href="http://www.greensolarcities.com/">http://www.greensolarcities.com/</a>
/2/	<a href="http://www.greensolarcities.com/demoprojects/salzburg/">http://www.greensolarcities.com/demoprojects/salzburg/</a>
/3/	<a href="https://www.salzburg.gv.at/bauenwohnen_/Documents/wohnbauforschungsprojekt_stadt_werk_lehen_publicierbarer_endbericht_2014.pdf">https://www.salzburg.gv.at/bauenwohnen_/Documents/wohnbauforschungsprojekt_stadt_werk_lehen_publicierbarer_endbericht_2014.pdf</a>
/4/	<a href="http://www.prisma-zentrum.com/standorte/salzburg/stadtwerk/standort/">http://www.prisma-zentrum.com/standorte/salzburg/stadtwerk/standort/</a>

### Chapter 4.4: Solar-assisted urban quarter “Freiburg-Gutleutmatten”, DE

/1/	<a href="http://www.freiburg.de/pb/,Lde/208548.html">http://www.freiburg.de/pb/,Lde/208548.html</a>
/2/	<a href="https://www.badenovawaermeplus.de/web/Erneuerbare-Energien/Sonne/Anlagen/Solarthermie-Gutleutmatten.jsp">https://www.badenovawaermeplus.de/web/Erneuerbare-Energien/Sonne/Anlagen/Solarthermie-Gutleutmatten.jsp</a>

### Chapter 4.5: Solar-assisted residential area “Vallda Heberg” in Kungsbacka, SE

/1/	Fahlén, E., Olsson, H., Sandberg, M., Löfås, P., Kilersjö, C., Christensson, N., Jessen, P.A., 2014. Vallda Heberg - Sveriges största passivhusområde med förnybar energi. Göteborg.
/2/	Olsson, H., Rosander, A., 2014. Evaluation of the Solar-Assisted Block Heating System in a Passive House Residential Area - A Master 's Thesis in Sustainable Energy Systems Chalmers University of Technology.



/3/	Nielsen, C., Haegermark, M., Dalenbäck, J.O., 2014. Analysis of a Novel Solar District Heating System. Eurosun 2014 16–19. doi:urn:nbn:se:du-15517
/4/	<a href="http://www.buildup.eu/en/practices/cases/vallda-heberg-swedish-certified-passive-house-residential-area">http://www.buildup.eu/en/practices/cases/vallda-heberg-swedish-certified-passive-house-residential-area</a>
/5/	<a href="https://www.ncc.se/vara-projekt/vallda-heberg-kungsbacka">https://www.ncc.se/vara-projekt/vallda-heberg-kungsbacka</a> (Swedish only)

#### Chapter 4.6: Solar assisted apartment blocks “La Cigale” in Geneva, CH

/1/	For further information on the “La Cigale” IceSol system visit: <a href="http://task44.iea-shc.org/">http://task44.iea-shc.org/</a>
/2/	Tornare G., Elio R, Barras G., and al., « Rapport technique et de communication du projet d’assainissement Minergie-P des immeubles « La Cigale » (GE) – Chauffage par pompes à chaleur solaires couplées à des stocks à changement de phase », Rapport final – DRAFT, OFEN, December 2016, Bern
/3/	Thissen B., « La Cigale – Projet de rénovation : Chauffage par pompe à chaleur solaires couplées à des stocks à changement de phase – retour d’expérience », ER’17 Symposium, March 2017, Yverdon

#### Chapter 4.7: Solar-assisted mountain holiday resort “Reka Feriendorf” in Naters, CH

/1/	Sulzer M., Summermatter S.: «Solare Energieversorgung im alpinen Raum - Reka-Feriendorf Blatten-Belalp», Schlussbericht, December 2015, BFE, Bern
-----	---

#### Chapter 4.8: Solar-assisted urban quarter “Buchsee-Köniz” in Berne, CH

/1/	<a href="http://www.energiestadt.ch/">http://www.energiestadt.ch/</a>
/2/	Entwurfsplanung Solarunterstützung "Buchsee-Quartier Köniz", 06.10.2015, BKW, author: S.O.L.I.D

#### Chapter 4.9: Solar-assisted urban quarter “Renens-CFF” in the suburb of Lausanne; CH

/1/	<a href="http://cadouest.ch">http://cadouest.ch</a>
/2/	Loi sur l’énergie (LVLEne) 730.01, 16 mai 2006
/3/	<a href="http://www.dgnb-system.de/en/">http://www.dgnb-system.de/en/</a>